



**IMPULSE / SURGE TESTER
7700 / 7710 / 7720**

User Manual

Issue B

3rd May 2006

Part N° 9H7700

Contents

1. SAFETY	1-4
1.1 General.....	1-4
1.2 AC Power Supply.....	1-5
1.3 Adjustment, Maintenance and Repair.....	1-5
1.4 Static Electricity.....	1-6
2. INTRODUCTION	2-1
2.1 Package and Accessories.....	2-1
2.1.1 7700.....	2-1
2.1.2 7710.....	2-1
2.1.3 7720.....	2-1
3. INSTALLATION	3-1
3.1 AC Line Connections.....	3-1
3.2 Location.....	3-1
3.3 Measurement Connections.....	3-1
3.4 Safety Interlock.....	3-2
4. OPERATION	4-1
4.1 The Front Panel.....	4-1
4.2 The Rear Panel.....	4-2
4.3 Product Identification.....	4-3
4.3.1 Ready State.....	4-3
4.4 Keyboard.....	4-3
4.4.1 System Control.....	4-3
4.4.2 Function.....	4-3
4.4.3 Edit.....	4-3
4.4.4 Enter.....	4-4
4.4.5 Test.....	4-4
4.4.6 Screen Soft Keys.....	4-4
4.5 Function Menu.....	4-4
4.5.1 Self-Test.....	4-4
4.5.2 SYS. INFO.....	4-5
4.5.3 H/V CAL. and H/V TEST.....	4-5
4.6 System Setup Menu.....	4-5
4.6.1 SYSTEM.....	4-6
4.6.2 GRAPHICS.....	4-8
4.6.3 DATE TIME.....	4-9
4.6.4 PASSWORD.....	4-9
4.7 Test Programs.....	4-10
4.7.1 File Menu.....	4-10
4.7.2 Filename Character Entry.....	4-10
4.7.3 Creating a Test Program File.....	4-10
4.7.4 Edit an Existing Test Program.....	4-11
4.7.5 Deleting a Test Program.....	4-11

4.7.6	Sorting	4-11
4.7.7	View Mode	4-12
5.	TESTING A NEW COMPONENT	5-1
5.1	Create a New Test Program File	5-1
5.2	Test Voltage	5-1
5.2.1	Example of Establishing the Test Voltage	5-1
5.3	Test Mode Menu	5-1
5.3.1	Test Mode	5-1
5.3.2	Dummy Pulse	5-2
5.3.3	Testing Pulse	5-2
5.4	Creating the Standard Waveform	5-2
5.4.1	Safety Interlock	5-2
5.4.2	Learning a Component	5-2
5.5	Selecting the Test Parameters	5-3
5.6	Setting the Test Parameters	5-3
5.6.1	Waveform Area Size Setup	5-4
5.6.2	Differential Area Size Setup	5-4
5.6.3	Flutter Value Setup	5-5
5.6.4	Waveform Comparison Setup	5-6
5.6.5	Optimizing the Test Parameter Settings	5-7
6.	COMPONENT TESTING	6-1
6.1	Test Statistics	6-2
7.	REMOTE CONTROL	7-1
7.1	Serial Port	7-1
7.1.1	Protocol	7-1
7.1.2	Serial Port Connections	7-1
7.1.3	REMOTE CONTROL SIGNAL	7-1
7.1.4	Commands	7-2
7.2	Handler Port	7-4
7.2.1	Pin Assignment	7-4
7.2.2	Port Timing	7-5
8.	THEORY OF OPERATION	8-1
8.1	Applied Pulse	8-1
8.2	Why Use Impulse Testing?	8-1
9.	HIGH VOLTAGE CALIBRATION & TEST	9-1
9.1	High Voltage Calibration	9-1
9.2	High Voltage Test	9-2
10.	SPECIFICATION	10-1
10.1	Measurement Ports	10-1
10.2	Advanced Functions	10-1
10.3	Testing Functions	10-1
10.4	Voltage Pulse	10-1
10.5	Measuring Time	10-1

10.6	Waveform Resolution	10-1
10.7	Display/Audio	10-2
10.8	Interface	10-2
10.9	Memory	10-2
10.10	Power Supply	10-2
10.11	Accessories	10-2
10.12	Thermo/Humidity	10-2
10.13	Size	10-2
10.14	Weight	10-2
10.15	Options	10-3
11.	MAINTENANCE, SUPPORT AND SERVICES	11-1
11.1	Guarantee	11-1
11.2	Maintenance	11-1
11.2.1	Cleaning	11-1
11.2.2	Safety Checks	11-1
11.3	Support and Service	11-2

1. Safety

1.1 General

This equipment has been designed to meet the requirements of EN61010-1 'Safety requirements for electrical equipment for measurement, control & laboratory use' and has left the factory in a safe condition.

The following definitions in EN61010-1 are applicable:

OPERATOR	Person operating equipment for its intended purpose. Note: The OPERATOR should have received training appropriate for this purpose.
RESPONSIBLE BODY	Individual or group responsible for the use and maintenance of equipment and for ensuring that operators are adequately trained.

The RESPONSIBLE BODY must ensure that this equipment is only used in the manner specified. If it is not used in such a manner, the protection provided by the equipment may be impaired.

This product is not intended for use in atmospheres which are explosive, corrosive or adversely polluted (e.g. containing conductive or excessive dust). It is not intended for use in safety critical or medical applications.

The equipment can cause hazards if not used in accordance with these instructions. Read them carefully and follow them in all respects.

Do not use the equipment if it is damaged. In such circumstances the equipment must be made inoperative and secured against any unintentional operation.

MICROTEST ELECTRONICS and the associated sales organizations accept no responsibility for personal or material damage, or for any consequential damage that results from irresponsible or unspecified operation or misuse of this equipment.

1.2 AC Power Supply

Power cable and connector requirements vary between countries. Always use a cable that conforms to local regulations, terminated in an IEC320 connector at the instrument end.

If it is necessary to fit a suitable AC power plug to the power cable, the user must observe the following colour codes:

WIRE	EUROPEAN	N. AMERICAN
LIVE	BROWN	BLACK
NEUTRAL	BLUE	WHITE
GROUND	GREEN/YELLOW	GREEN

The user must also ensure that the protective ground lead would be the last to break should the cable be subject to excessive strain.

If the plug is fused, a 3-amp fuse should be fitted.

If the power cable electrical connection to the AC power plug is through screw terminals then, to ensure reliable connections, any solder tinning of the cable wires must be removed before fitting the plug.

Before switching on the equipment, ensure that it is set to the voltage of the local AC power supply.

WARNING!

Any interruption of the protective ground conductor inside or outside the equipment or disconnection of the protective ground terminal is likely to make the equipment dangerous. Intentional interruption is prohibited.

1.3 Adjustment, Maintenance and Repair

WARNING!

The equipment must be disconnected from all voltage sources before it is opened for any adjustment, replacement, maintenance, or repair.

When the equipment is connected to the local AC power supply, internal terminals may be live and the opening of the covers or removal of parts (except those to which access can be gained by hand) is likely to expose live parts.

Capacitors inside the equipment may still be charged even if the equipment has been disconnected from all voltage sources.

Any adjustment, maintenance, or repair of the opened equipment under voltage must be carried out by a skilled person who is aware of the hazards involved.

Service personnel should be trained against unexpected hazards.

Ensure that only fuses with the required rated current and of the specified type are used for replacement. The use of makeshift fuses and short-circuiting of fuse holders is prohibited.

1.4 Static Electricity

The unit supplied uses static-sensitive devices. Service personnel should be alerted to components which require handling precautions to avoid damage by static electrical discharge.

Before handling circuit board assemblies containing these components, personnel should observe the following precautions:

- 1) The work surface should be a conductive grounded mat.
- 2) Soldering irons must be grounded and tools must be in contact with a conductive surface to ground when not in use.
- 3) Any person handling static-sensitive parts must wear a wrist strap which provides a leaky path to ground, impedance not greater than $1M\Omega$.
- 4) Components or circuit board assemblies must be stored in or on conductive foam or mat while work is in progress.
- 5) New components should be kept in the supplier's packaging until required for use

2. Introduction

The 7700 series of Winding Testers provide a non-destructive way to test windings using a high voltage pulse of between 500V and 10kV. By comparing the decay waveforms with a standard winding, deviation in core material, number of turns, shorted turns, and insulation breakdown can be identified.

The tester's measurement, display and control facilities include:

- memory for up to 200 standard windings
- auto learn for standard windings
- waveform area, differential area, flutter and waveform comparison
- full statistics for each winding stored in memory
- output of measurements and statistics to an Epson-compatible printer
- built-in High Voltage calibration and test
- the unit may be locked in test mode

2.1 Package and Accessories

2.1.1 7700

- 7700 Impulse Winding Tester
- 2 terminal
- Power cord and Connector

2.1.2 7710

- 7700 Impulse Winding Tester
- 2 terminal
- Power cord and Connector

2.1.3 7720

- 7720 Impulse Winding Tester
- 8 terminal
- Power cord and Connector

3. Installation

3.1 AC Line Connections

The unit is provided with a power cable capable of carrying the input current for both 115V and 230V operation. This cable should be connected via a suitable connector to the local AC power supply. The colour code employed is as follows:

WIRE	EUROPEAN	N. AMERICAN
LIVE	BROWN	BLACK
NEUTRAL	BLUE	WHITE
GROUND	GREEN/YELLOW	GREEN

Figure 3-1 AC Power Cable Codes

The supply voltage setting can be checked by looking on the rear panel next to the power inlet socket. Ensure that the unit is not connected to the power supply. Adjust the switch to read the required voltage. No adjustment is required for variation of supply frequency.

Before connecting the AC power, read the precautions listed under section 1.2 AC Power Supply.

The power switch is located on the left of the front panel.

The instrument is not suitable for battery operation.

3.2 Location

The instrument is intended for use on the bench. The power modules are fan cooled and care must be taken not to restrict any of the air paths. Ensure that the unit is located in an area appropriate for the hazardous voltages produced when testing components. See sections 3.3 and 3.4.

3.3 Measurement Connections

WARNING!

This equipment is intended for use by suitably trained and competent persons.

This product is capable of having hazardous voltages (up to 10kV) on its terminals in normal use. Appropriate safety precautions should be taken.

This product can cause hazards if it is not used in accordance with these instructions. Read them carefully and follow them in all respects. Double check connections to the unit before use.

DO NOT USE THIS EQUIPMENT IF IT IS DAMAGED.

For maximum user safety, it recommended that a safety interlock is used.

3.4 Safety Interlock

WARNING!
HIGH VOLTAGE

This product is capable of having hazardous voltages (up to 10kV) on its terminals in normal use. Appropriate safety precautions should be taken.

A high voltage pulse, or pulses, is applied during testing. The front panel High Voltage (H.V.) LED will light whenever a high voltage pulse is applied to the component under test.

**ENSURE THAT THE COMPONENT UNDER TEST AND TEST LEAD
TERMINATIONS CANNOT BE TOUCHED DURING THE TEST CYCLE.**

The High Voltage (H.V.) output is inhibited until the safety interlock circuit is complete. The terminal fixture for the winding under test should be placed within ahousing with an interlocked door controlled by a circuit such as that shown in Figure 3-2.

Resistor R should be $< 1k\Omega$.

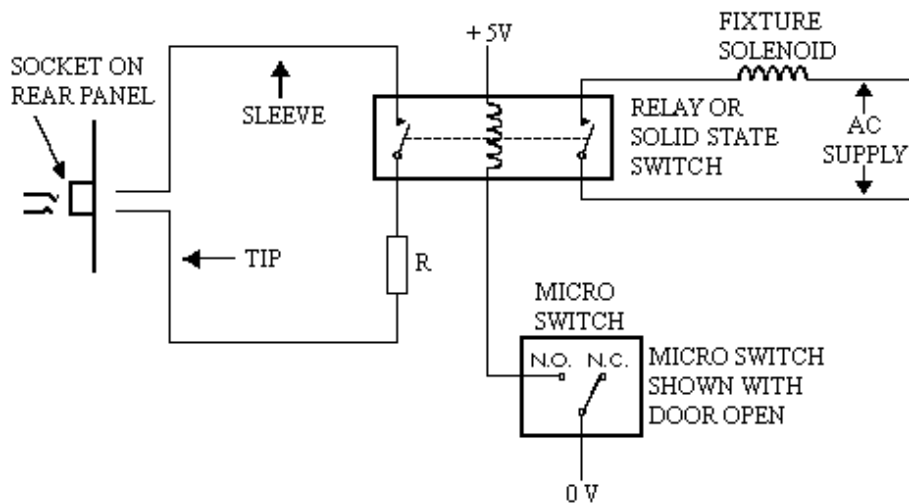

Figure 3-2 Typical High.Voltage(H.V.) Interlock Fixture

When the fixture door is closed, and the micro switch therefore made, the High Voltage output is activated via the relay. The relay also energizes an AC supply for a solenoid which can be used to lock the door while the High Voltage output is on.

4. Operation

WARNING!

This equipment is intended for use by suitably trained and competent persons.

This product is capable of having hazardous voltages (up to 10kV) on its terminals in normal use. Appropriate precautions should be taken for safety.

This product can cause hazards if it is not used in accordance with these instructions. Read them carefully and follow them in all respects. Double check connections to the unit before use.

READ SECTIONS 1 and 3 OF THIS MANUAL BEFORE USING THE 7720.

DO NOT USE THIS EQUIPMENT IF IT IS DAMAGED.

4.1 The Front Panel

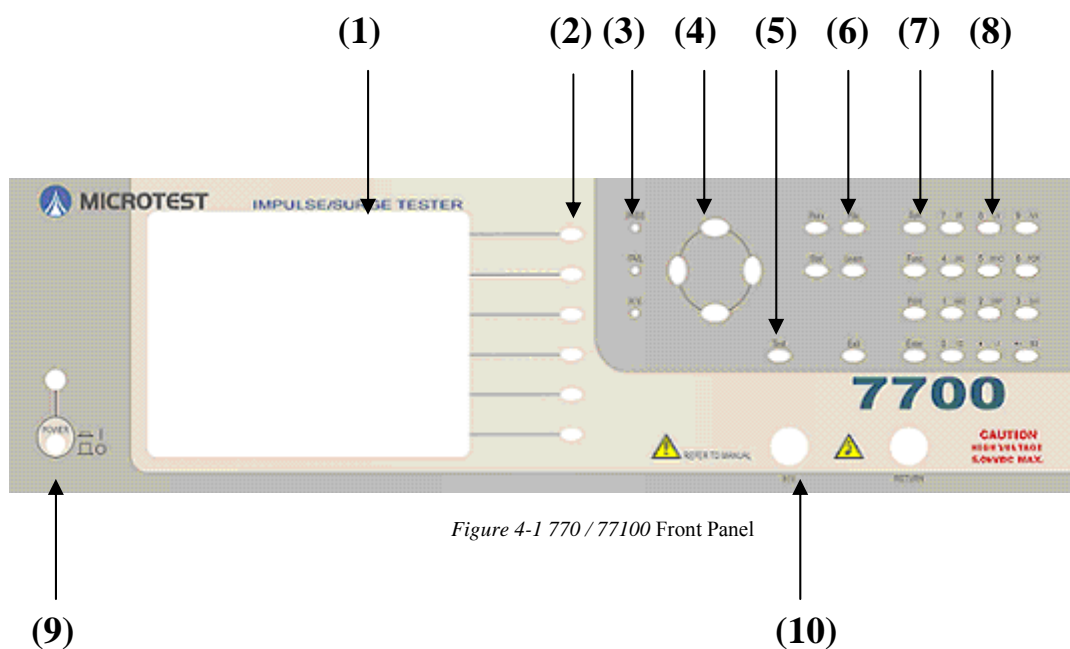

Figure 4-1 770 / 77100 Front Panel

- (1) LCD Display
- (2) S1~S6 Soft Key
- (3) PASS & FAIL & H.V.Indicator
- (4) Edit Keys
- (5) Measure Key [TEST]
- (6) Function Keys
- (7) SysKey
- (8) Alpha-Numerical Keys

- (9) Power on/off switch
- (10) 2 terminals high voltage testing connector

4.2 The Rear Panel

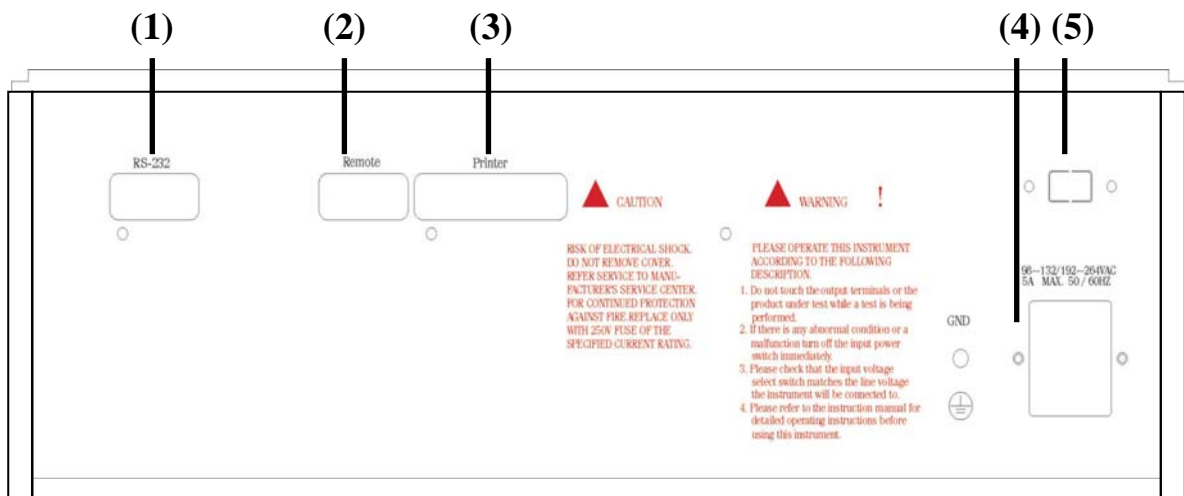

Figure 4-2 Rear Panel

- (1) Serial Port (RS-232 Port)
- (2) Remote Control Port (Handler Port)
- (3) Printer Connection Port (Printer Port)
- (4) AC Input (230/115 VAC)
- (5) AC Input 115 or 230V Selection Switch

Note

Before connecting to the AC power source ensure that the selector switch (5) is set to the correct voltage.

Ensure that the AC power source is always grounded.

4.3 Product Identification

A self testing program is executed when the instrument is initially switched on. At the end of the self test the instrument displays the product identification graphic.

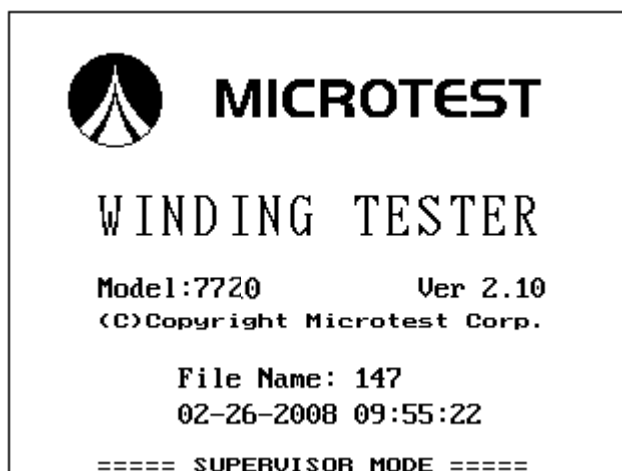

Figure 4-3 7720 Product Identification

4.3.1 Ready State

At the ready state the soft keys have the following capabilities:

- S1 Brighten LCD backlight
- S2 Dim LCD backlight
- S6 System Information

4.4 Keyboard

4.4.1 System Control

- [Func] Function Menu
- [Sys] System Setup Menu
- [Print] Printing Function

4.4.2 Function

- [File] File Management
- [Learn] Learn Waveform
- [Item] Set Item
- [Stat] Statistic Report

4.4.3 Edit

- Alpha Numeric Data 0~1, A~Z, . /
- [BS] (←) Back Space Key

- Cursor [←] [→] Navigation
- Cursor [↑] [↓] Navigation
- Cursor [PgUp] [PgDn] Navigation
- [Exit] Previous menu

4.4.4 Enter

Confirm Data Entered

4.4.5 Test

Start Device Testing

4.4.6 Screen Soft Keys

S1 to S6 are located at the right side of the display. Each key function is menu dependant.

4.5 Function Menu

Pressing the front panel **Func** key will display the FUNCTION menu. Select an option by pressing the appropriate alphanumeric key or by using the ▲ and ▼ navigation keys to highlight the option and then press **Enter**.

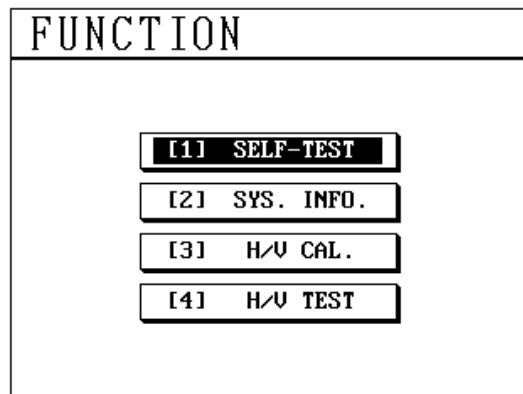

Figure 4-4 Function Menu

4.5.1 Self-Test

To run self test press **Enter** when the SELF-TEST option is highlighted. Use the ▲ and ▼ navigation keys to select the required option or press the alphanumeric **1** key.

The self-test will now run and display the test results. Figure 4-5 shows the SELF-TEST result screen with all tests passed.

Press the SKIP soft key to disable any test. If the unit fails any stage of the self-test please contact Microtest.

SELFTEST	
ITEM	TEST
[1] CPU	OK
[2] RAM	OK
[3] ROM	OK
[4] EEPROM	OK
[5] CLOCK	OK

SKIP

EXIT

Figure 4-5 Self Test Menu

Use the EXIT soft key or the **Exit** key to return to the FUNCTION menu.

4.5.2 SYS. INFO

To display system information press **Enter** when the SYS. INFO. option is highlighted. Use the **▲** and **▼** navigation keys to select the required option or press the alphanumeric **2** key.

The system information will now be displayed on the screen and includes file space available, software and hardware versions. Some of this information may be requested if Microtest is contacted for assistance with the unit.

SYSTEM INFO.	
[1] MODEL	7720
[2] SOFTWARE VERSION	1.3 (5KV)
[3] EDITION	STANDARD
[4] RELEASED DATE	Mar 27 2005
[5] HARDWARE VERSION	1.5
[6] TOTAL FILE SPACE	80
[7] FREE FILE SPACE	77

EXIT

Figure 4-6 System Information Menu

Press the EXIT soft key or the **Exit** key to leave the SYSTEM INFO screen.

4.5.3 H/V CAL. and H/V TEST

Refer to Chapter 9 for High Voltage Calibration and Test procedures.

4.6 System Setup Menu

Pressing the front panel **Sys** key will display the SYSTEM SETUP menu. Select an option by pressing the appropriate alphanumeric key or by using the **▲** and **▼** navigation keys, to highlight the option and then press **Enter**.

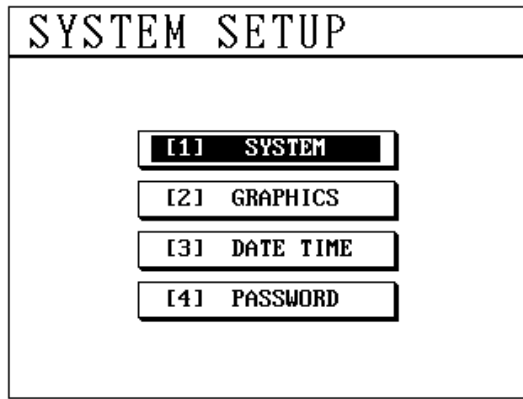

Figure 4-7 System Set-up Menu

4.6.1 SYSTEM

To display the SYSTEM SETUP sub-menu press **Enter** when the SYSTEM option is highlighted. Use the ▲ and ▼ navigation keys to select the required option or press the alphanumeric **1** key.

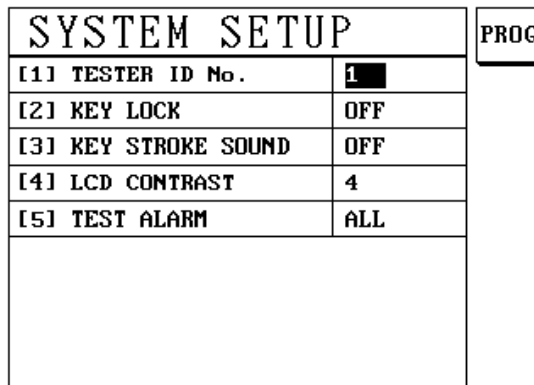

Figure 4-8 System Set-up Sub-Menu

TESTER ID No.

The **TESTER ID No.** can be changed to identify the unit. This is useful when analysing results from more than one tester. To change the number:

- 1) Move the highlight to the existing number with the ▲ and ▼ navigation keys.
- 2) Type in the new number; up to three digits may be entered.

KEY LOCK

Prevents unauthorized users accessing the test set-up. A password must be entered when switching the key lock on or off. See section 4.6.4 for details on how to change the **KEY LOCK** password.

To change the key lock state:

- 1) Move the highlight to the KEY LOCK option with the ▲ and ▼ navigation keys.
- 2) Press either of the ◀ or ▶ navigation keys, or the PROG soft key: the CHECK PASSWORD box, shown below, will be displayed.
- 3) Enter the correct password, then press **Enter**. The key lock will now be set to the opposite state.



Figure 4-9 Key Lock Password

KEY STROKE SOUND

When set to ON the **KEY STROKE SOUND** option enables a beep for each key press. To change the KEY STROKE SOUND state:

- 1) Move the highlight to the KEY STROKE SOUND option with the ▲ and ▼ navigation keys.
- 2) Press either the ◀ or ▶ navigation keys, or PROG soft key to set the opposite state.

LCD CONTRAST

The **LCD CONTRAST** is set by highlighting the option with the ▲ and ▼ navigation keys. Use the ◀ or PROG soft key to lighten the screen, or ▶ to darken it. Range: 1 – 8. Default: 5.

TEST ALARM

The **TEST ALARM** is set by highlighting the option with the ▲ and ▼ navigation keys. Use the ◀ and ▶ navigation keys or the PROG soft key to change the setting. There are four settings as shown in Figure 4-10. The alarm will sound when the corresponding state is indicated during a Test.

Setting	Alarm
NO	NO test alarms
ALL	test alarms for both PASS and FAIL
PASS	test alarm for PASS only
FAIL	test alarm for FAIL only

Figure 4-10 Test Alarm Options

4.6.2 GRAPHICS

To display the GRAPHICS SETUP menu press **Enter** when the GRAPHICS option is highlighted. Use the **▲** and **▼** navigation keys to select the required option or press the alphanumeric **2** key.

GRAPHICS SETUP		PROG
[1] STANDARD WAVE	LINE	
[2] D.U.T. WAVE	DOT	
[3] COMPARISON MASK	OFF	DEF-
[4] CENTER LINE	ON	AULT
[5] GRID	OFF	
		EXIT

Figure 4-11 Graphics Set-Up Menu

STANDARD WAVE

The **STANDARD WAVE** can be shown on the test screen in either a line or dot format, or can be turned off.

To change the STANDARD WAVE setting:

- 1) Move the highlight to the STANDARD WAVE option with the **▲** and **▼** navigation keys.
- 2) Press either the **◀** or **▶** navigation keys, or the PROG soft key to change the setting.

D.U.T. WAVE

The **D.U.T. WAVE** can be shown on the test screen in either a line or dot format. To change the D.U.T. WAVE setting:

- 1) Move the highlight to the D.U.T. WAVE option with the **▲** and **▼** navigation keys.
- 2) Press either the **◀** or **▶** navigation keys, or the PROG soft key to change the setting.

COMPARISON MASK

If **COMPARISON MASK** is set ON and WAVEFORM COMPARISON is selected (see section 5.6.4), the upper and lower limit waveform will be displayed.

To change the COMPARISON MASK setting:

- 1) Move the highlight to the COMPARISON MASK option with the **▲** and **▼** navigation keys.
- 2) Press either the **◀** or **▶** navigation keys, or the PROG soft key to change the setting.

CENTRE LINE and GRID

The **CENTRE LINE** and **GRID**, shown in the TEST display, can be turned ON or OFF as follows:

- 1) Move the highlight to the required option with the ▲ and ▼ navigation keys.
- 2) Press either the ◀ or ▶ navigation keys, or the PROG soft key to change the setting.

4.6.3 DATE TIME

To display the SET TIME menu press **Enter** when the **DATE TIME** option is highlighted (use the ▲ and ▼ navigation keys to select the required option), or press the alphanumeric **3** key.

```

SET TIME
-----
DATE: MM-DD-YY
TIME: HH:MM:SS

OLD DATE: 02-25-02
OLD TIME: 10:27:15

NEW DATE: 07-25-01
NEW TIME: 10:27:04

SET
EXIT
  
```

Figure 4-12 Set Time Menu

The date and time may be set using the navigation and alphanumeric keys. Once the correct date and time is entered, press the SET and EXIT soft keys to return to the SYSTEM SETUP menu.

4.6.4 PASSWORD

To display the CHECK/SET PASSWORD text box press **Enter** when the PASSWORD option is highlighted. Use the ▲ and ▼ navigation keys to select the required option or press the alphanumeric **4** key.

```

SYSTEM SETUP
-----
SET PASSWORD
NEW PSW [ ]

SYSTEM SETUP
-----
CHECK PASSWORD
PASSWORD [ ]

SYSTEM SETUP
-----
SET PASSWORD
CONFIRM [ ]
  
```

Figure 4-13 Key Lock Password Entry

This option modifies the password for the KEY LOCK function and system password. The factory default password is 7720.

To change the password:-

- 1) Enter the old password and then press the front panel **Enter** key.

- 2) Enter the new password and then press the front panel **Enter** key.
- 3) Re-enter the new password again and press the front panel **Enter** key.

4.7 Test Programs

Each component to be tested requires a test file to be created which includes the test parameter settings and the learnt waveform from a known good working 'golden' component. The learnt (standard) waveform provides the comparison data to which subsequent components are compared.

Test files may be uploaded to a PC or retrieved using the serial interface.

4.7.1 File Menu

To enter the FILE menu press the front panel **File** short-cut key.

F I L E				Total 3 file(s)	NEW
No.	Name	Date	Time		TEST
1	6815	07-25-01	10:34		EDIT
2	117	07-25-01	10:34		DEL.
3	NONAME	07-25-01	10:33		SORT
					VIEW MODE

Figure 4-14 File Menu

4.7.2 Filename Character Entry

Use the navigation the ◀ or ▶ navigation keys to select the position of the character to be entered and the numeric keypad to enter the number or character.

For example the key which is used to enter the number 1 is also used to enter A, B or C. Continue to operate the key until the desired character is displayed and then press the ▶ navigation key to enter the next character.

Once all the characters are entered use the **Enter** key to confirm the file name.

4.7.3 Creating a Test Program File

- 1) Press the NEW soft key.
- 2) Enter a file name of up to eight characters in the CREATE NEW FILE box using the alphanumeric keys and the ◀ or ▶ navigation keys. Press **Enter** to confirm the file name.

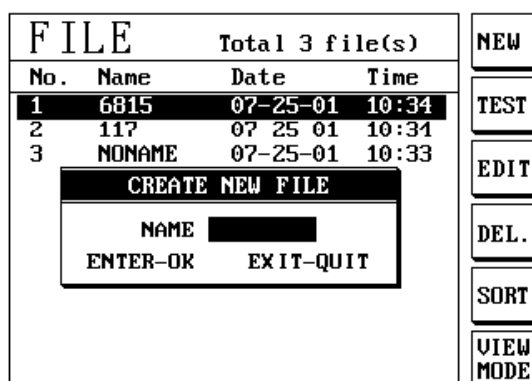

Figure 4-15 Creating a New File

The unit is now ready for the standard waveform to be learnt and the Test Parameters to be entered. See Chapter 5 for more information.

4.7.4 Edit an Existing Test Program

Enables modification of existing test program parameters or to learn a known good working 'golden' sample component.

- 1) Enter the FILE menu by pressing the front panel **File** key.
- 2) Use the ▲ and ▼ navigation keys to highlight the required file.
- 3) Press the EDIT soft key and the Test Parameter menu will be displayed.

4.7.5 Deleting a Test Program

To delete a file:

- 1) Use the ▲ and ▼ navigation keys to highlight the required file.
- 2) Press the DEL soft key: the DELETE FILE box, shown below, will be displayed.
- 3) Press the front panel **Enter** key to confirm the file deletion, or press **Exit** to cancel the file deletion and return to the FILE menu.

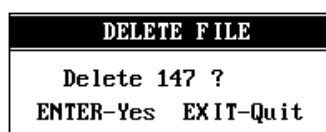

Figure 4-16 Delete File Menu

4.7.6 Sorting

While in the FILE menu, the files can be sorting by four different criteria by repeatedly pressing the SORT soft key. The sort options are:-

- Ascending by name or date
- Descending by name or date

4.7.7 View Mode

The date and time file information may be displayed or hidden using the VIEW MODE soft key.

FILE				Total 3 file(s)	NEW
No.	Name	Date	Time		TEST
1	6815	07-25-01	10:34		EDIT
2	147	07-25-01	10:34		DEL.
3	NONAME	07-25-01	10:33		SORT
					VIEW MODE

FILE				Total 3 file(s)	NEW
Date: 07-25-01		Time: 10:34			TEST
6815	147	NONAME			EDIT
					DEL.
					SORT
					VIEW MODE

Figure 4-17 View Mode

5. Testing a New Component

To test a new component a standard waveform has to be learnt for each test step from a known good 'golden' sample and then the optimum test parameter settings established by testing a quantity, of golden sample components.

The test parameters define the expected variation of component characteristics.

5.1 Create a New Test Program File

- 1) Enter the FILE menu by pressing the front panel **File** short-cut key.
- 2) Create a new file as described in section 4.7.3
- 3) The instrument will then enter the 'Learn' mode screen.

5.2 Test Voltage

The applied test voltage pulse must be set to a level that will ensure that faulty components are detected, yet set not too high to cause component damage.

ALWAYS CONSULT THE COMPONENT TEST SPECIFICATION PRIOR TO SETTING THE TEST VOLTAGE LEVEL.

- 1) Highlight the voltage level using the ▲ and ▼ navigation keys.
- 2) Enter the test level using the front panel keypad.
- 3) Press **Enter** to confirm.

5.2.1 Example of Establishing the Test Voltage

A coil with a nominal working voltage of 220V used a test voltage of 1.5KV which was derived from the formula $220 \times 1.414 \times 5$. The applied voltage was well within the maximum voltage level that could be applied to the component yet enabled manufacturing faults to be identified.

5.3 Test Mode Menu

Enter the Test Mode menu by selecting 'Mode' from the Learn menu. Use the ▲ and ▼ navigation keys to select the mode parameter to be modified.

The EXIT soft key returns to the LEARN menu.

5.3.1 Test Mode

The Test Mode menu is used to modify the pulse applied dependant on the characteristics of the component to be tested. The options 'NORMAL', 'LOW Q', 'LOW L' and 'LOW LQ' may be set using the PROG soft key.

The majority of components will use the 'NORMAL' setting and this is recommended for learning a component for the first time.

5.3.2 Dummy Pulse

The Dummy Pulse facility pre-magnetises a component and may be useful where a residual magnetic field is present prior to applying the test pulse.

5.3.3 Testing Pulse

The alphanumeric keypad is used to set the number of Pulses generated when testing a component.

5.4 Creating the Standard Waveform

WARNING!

HIGH VOLTAGE

This product is capable of having hazardous voltages (up to 10kV) on its terminals in normal use. Appropriate safety precautions should be taken.

A high voltage pulse, or pulses, is applied during testing. The front panel High Voltage (H.V.) LED will light whenever a high voltage pulse is applied to the component under test.

ENSURE THAT THE COMPONENT UNDER TEST AND TEST LEAD TERMINATIONS CANNOT BE TOUCHED DURING THE TEST CYCLE.

The unit tests components by comparing each test result standard waveform(s) learned from a known good 'golden' sample..

5.4.1 Safety Interlock

The High Voltage (H.V.) output is inhibited until the safety interlock circuit is complete. Place a 'golden' sample in the safety enclosure and connect the instrument to the component/enclosure. Close the safety door to complete the Safety Interlock circuit. For more information see section 3.4.

5.4.2 Learning a Component

- 1) Press the LEARN/TRIG soft key or the front panel **Learn** key: the component will be tested and its waveform will be displayed. The front panel H.V. LED (High Voltage) will illuminate when the high voltage pulse is applied to the component.
- 2) Use the zoom in and zoom out soft keys if the waveform displayed is not as required.

The waveform displayed will vary dependant upon the component being learnt. Use the Zoom soft keys to ensure that at least one complete cycle of the waveform is displayed. After each change of waveform the unit will prompt the user to press the TRIG key to test the standard component at the new settings.

5.5 Selecting the Test Parameters

TEST PARAMETER		ON
PARAMETER	TEST	OFF
[1] WAVEFORM AREA SIZE	<input checked="" type="checkbox"/>	SET-UP
[2] DIFFERENTIAL AREA SIZE	<input checked="" type="checkbox"/>	
[3] FLUTTER VALUE	<input checked="" type="checkbox"/>	
[4] WAVEFORM COMPARISON	<input checked="" type="checkbox"/>	
FILE: NONAME		

Figure 5-1 7700 / 7710 2 Port Test Parameter Menu

TEST PARAMETER						ON
STEP	CHANNEL	AREA	DIFF	FLUT	COMP	OFF
* 1	1 - 2	<input checked="" type="checkbox"/>	<input checked="" type="checkbox"/>		<input checked="" type="checkbox"/>	SET-UP
* 2	3 - 4	<input checked="" type="checkbox"/>	<input checked="" type="checkbox"/>	<input checked="" type="checkbox"/>		
* 3	5 - 6	<input checked="" type="checkbox"/>	<input checked="" type="checkbox"/>		<input checked="" type="checkbox"/>	
* 4	7 - 8	<input checked="" type="checkbox"/>	<input checked="" type="checkbox"/>	<input checked="" type="checkbox"/>		
5	? - ?					
6	? - ?					
7	? - ?					
8	? - ?					

Figure 5-2 7720 8 Port Test Parameter Menu

Press the front panel **Para** key: the TEST PARAMETER menu will be displayed.

For each step highlight the individual test parameters required to be measured using the ▲ and ▼ navigation keys. Use either the ON or OFF soft key to select or remove the test.

The 7720 instruments with more than two channels have a multi step capability allowing the test channels to be specified for each step. For enhanced fault finding ability consider using for example 1 – 2 for step 1 followed by 2 – 1 for step 2.

Once the test parameters and channels, if applicable, have been chosen each parameter must be programmed by highlighting it with the ▲ and ▼ navigation keys and pressing the SET-UP soft key or by using the Para keyboard key.

5.6 Setting the Test Parameters

The Test Parameters define the expected variation of component characteristics compared to a stored learnt standard test waveform obtained from a known good ‘golden’ sample component. Any variation of waveform exceeding the entered parameters will fail the component under test.

If available use a ‘golden’ component sample, that was not used to produce the learnt standard waveform, to establish the initial parameter limits

When all the changes have been made save the settings by pressing the front panel TEST key.

Establishing the optimum parameter settings will involve testing a quantity of ‘golden’ samples and adjusting the tolerance levels as required. Use the **Para** key or the EDIT soft key from the FILE menu.

5.6.1 Waveform Area Size Setup

The **WAVEFORM AREA SIZE** test looks for a change in the area under the waveform but does not take into account any distortion or movement of the waveform.

With the **WAVEFORM AREA SIZE** test turned ON and selected with the cursor, press the SET-UP soft key: the **WAVEFORM AREA SIZE** set-up display (Figure 5-3 left) will be shown.

The **TOLERANCE** is set by typing in the required value with the alphanumeric keypad, followed by **Enter**.

The **TEST RANGE** (right) is set with the T1 and T2 soft keys.

Pressing the PRE-TEST soft key with a component connected to the unit’s test connectors will show the component characteristics superimposed on the standard waveform to allow an instant comparison. Adjustments can then be made to the **WAVEFORM AREA SIZE** set-up if required. See sections 3.3 and 3.4 for important safety information.

Press the EXIT soft key or the front panel **Exit** key to return to the **TEST PARAMETER** menu.

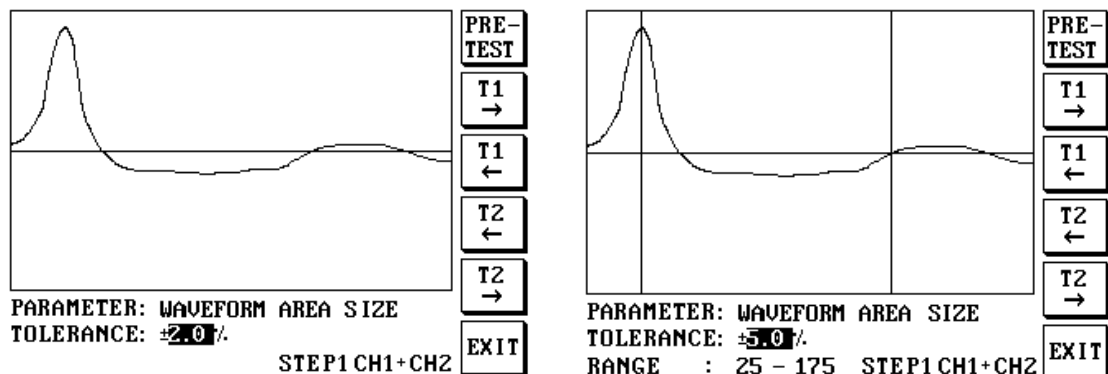

Figure 5-3 Waveform Area Size

5.6.2 Differential Area Size Setup

The **DIFFERENTIAL AREA SIZE** test looks for any movement or distortion outside the waveform but does not take into account any change in the area of the waveform.

With the **DIFFERENTIAL AREA SIZE** test turned ON and selected with the cursor, press the SET-UP soft key: the **DIFFERENTIAL AREA SIZE** set-up display (Figure 5-4) will be shown.

The **TOLERANCE** is set by typing in the required value with the alphanumeric keypad, followed by **Enter**.

The **TEST RANGE** is set with the T1 and T2 soft keys.

Pressing the PRE-TEST soft key with a component connected to the unit's test connectors will show the component characteristics superimposed on the standard waveform to allow an instant comparison. Adjustments can then be made to the **DIFFERENTIAL AREA SIZE** set-up if required. See sections 3.3 and 3.4 for important safety information.

Press the EXIT soft key or the front panel **Exit** key to return to the TEST PARAMETER menu.

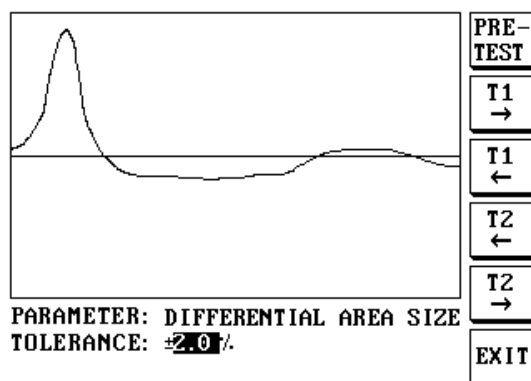

Figure 5-4 Differential Area Size

5.6.3 Flutter Value Setup

The **FLUTTER VALUE** calculates the number of level differences (corona discharges) from one waveform point to the next on a voltage waveform.

With the **FLUTTER VALUE** test turned ON and selected with the cursor, press the SET-UP soft key: the **FLUTTER VALUE** set-up display will be shown.

The corona COUNT value is set by typing in the required number with the alphanumeric keypad, followed by **Enter**.

The TEST RANGE is set with the T1 and T2 soft keys.

Pressing the PRE-TEST soft key with a component connected to the unit's test connectors will show the component characteristics superimposed on the standard waveform to allow an instant comparison. Adjustments can then be made to the **FLUTTER VALUE** set-up if required. See sections 3.3 and 3.4 for important safety information.

Press the EXIT soft key or the front panel **Exit** key to return to the TEST PARAMETER menu.

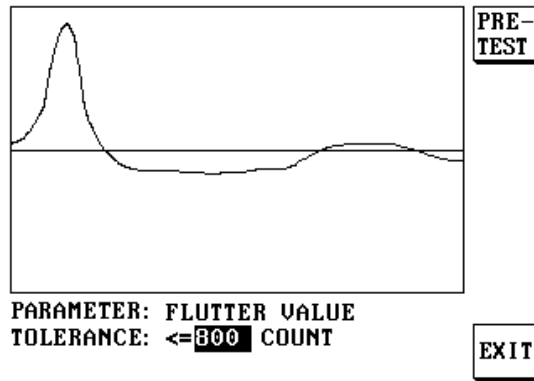

Figure 5-5 Flutter Value

5.6.4 Waveform Comparison Setup

WAVEFORM COMPARISON looks for a change in the waveform voltage or frequency.

With the **WAVEFORM COMPARISON** test turned ON and selected with the cursor, press the SET-UP soft key: the **WAVEFORM COMPARISON** set-up display (Figure 5-6) will be shown.

The TIME TOL and VOLTAGE TOL values are set by typing in the required value with the alphanumeric keypad, followed by **Enter**. Use the ◀ and ▶ keys to navigate between the two settings.

Pressing the PRE-TEST soft key with a component connected to the unit's test connectors will show the component characteristics superimposed on the standard waveform to allow an instant waveform comparison. To pass this test the waveform must be between the upper and lower waveforms displayed. See sections 3.3 and 3.4 for important safety information.

The TEST RANGE is set with the T1 and T2 soft keys.

Press the EXIT soft key or the front panel **Exit** key to return to the TEST PARAMETER menu.

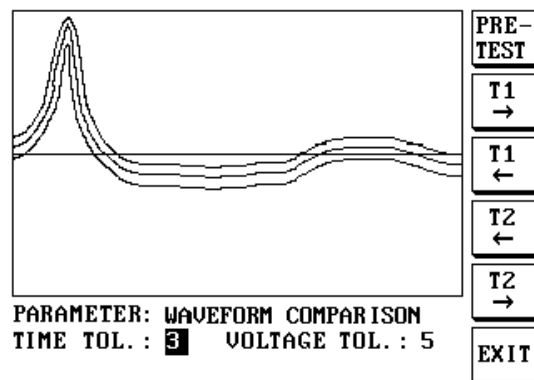

Figure 5-6 Waveform Comparison

5.6.5 Optimizing the Test Parameter Settings

To optimize the parameter settings a quantity of known good working golden samples will be required. It is recommended that at least five samples are used during optimization.

Test each sample and note the test differences compared to the learnt waveform.

Example Test Parameter Values

The final Test Parameter settings used are dependant on component design and manufacturing quality.

As a guide it is recommended that initially the Test Parameter tolerance be set to three times the average percentage variation of the 'golden' samples tested. Where a count is specified set the count to be the count plus 10%.

To modify the settings select the **Para** key or use the EDIT key in the File menu. Once parameter entry has been completed return to the file menu and select TEST.

6. Component Testing

WARNING!

HIGH VOLTAGE

This product is capable of having hazardous voltages (up to 10kV) on its terminals in normal use. Appropriate safety precautions should be taken.

A high voltage pulse, or pulses, is applied during testing. The front panel High Voltage (H.V.) LED will light whenever a high voltage pulse is applied to the component under test.

ENSURE THAT THE COMPONENT UNDER TEST AND TEST LEAD TERMINATIONS CANNOT BE TOUCHED DURING THE TEST CYCLE.

Prior to production testing a component a test file must be created for that component type, the standard waveform 'learnt' from a 'Golden' sample, and Test Parameters set and optimized. See Chapter 5 for more information.

- 1) Press the front panel **File** key and highlight the file required with the ▲ and ▼ navigation keys.
- 2) Press the TEST soft key and the standard component waveform will be displayed.
- 3) Connect the component to be tested using an enclosure incorporating a safety interlock circuit. See sections 3.3 and 3.4 for important safety information.
- 4) Press the front panel TEST key.

The front panel H.V. LED (High Voltage) will illuminate when the high voltage pulse is applied to the component.

When the test is complete PASS or FAIL is displayed on the screen together with the test results. The component waveform will be displayed, superimposed on the standard waveform. The PASS/FAIL front panel LEDs will also indicate the result of the test.

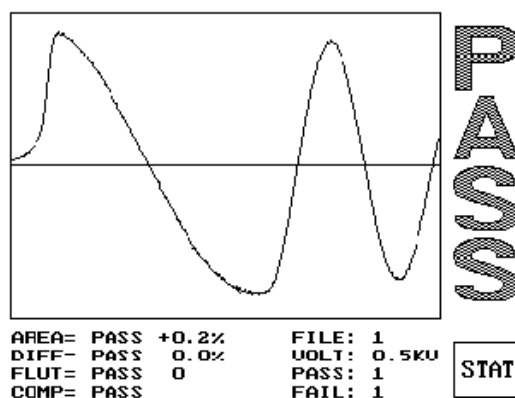

Figure 6-1 Test Result

6.1 Test Statistics

Pressing the STAT soft key or the front panel **Stat** key will show the test statistics of the currently loaded file. An example is shown below.

STATISTICS		QTY. RATE
TESTED	██████████	4
PASSED	██████████	4
FAILED		0
— FAIL ANALYSIS —		
AREA		0
DIFF.		0
FLUT.		0
COMP.		0
FILE: NONAME		

STATISTICS		QTY. RATE
TESTED	██████████	100.0%
PASSED	██████████	100.0%
FAILED		0.00%
— FAIL ANALYSIS —		
AREA		0.00%
DIFF.		0.00%
FLUT.		0.00%
COMP.		0.00%
FILE: NONAME		

Figure 6-2 Test Statistics

Press the QTY. RATE soft key to toggle between absolute and percentage statistics.

To clear the data press the CLR soft key.

The front panel **Print** key prints the screen display to an Epson-compatible printer.

Press the EXIT soft key or the front panel **Exit** key to return to the Test mode.

7. Remote Control

7.1 Serial Port

7.1.1 Protocol

Baud rate: 9600bps
 Character length: 8bits
 Stop bit: 1bit
 Parity: Non-parity
 Character: ASCII character

7.1.2 Serial Port Connections

Function	7220	Controller
RxD	Pin 2	Pin 3
TxD	Pin 3	Pin 2
GND	Pin 5	Pin 5
RTS	Pin 7	Pin 8
CTS	Pin 8	Pin 7

7.1.3 REMOTE CONTROL SIGNAL

PIN#	NAME	FUNC
1	CTL1	PASS
2	CTL2	FAIL
3	CTL3	H.V. ON
4	CTL4	TEST
5	CTL5	WIND 1
6	CTL6	WIND 2
7	CTL7	WIND 3
8	CTL8	WIND 4
9	V1	+12V
10	IN1	SW1
11	IN2	SW2
12	RST	RESET

13	V2	+5V
14	V3	+12V
15	GND	GROUND

SCHEMATIC

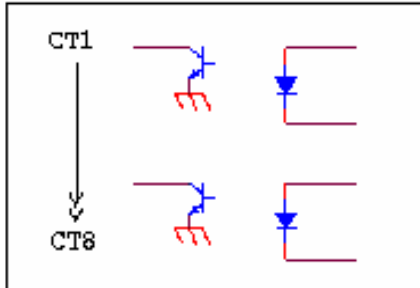

7.1.4 Commands

Commands are terminated by LF (line feed, ASCII code 10 (decimal), 0xA (hexadecimal)); only the LF is effective as the terminator.

Download (D)

D – reference file is sent from the computer to 7720

4608 bytes in length 4, 6 or 8 port instruments

512 bytes in length 2 port instruments

The command 'D' should be sent followed by LF. A delay of 100ms may be required before the file data is sent.

Upload (U)

U – reference file is sent from 7720 to the computer

4608 bytes in length 4, 6 or 8 port instruments

521 bytes in length 2 port instrument

System Key (Kn)

Kn - simulates the pressing of a specified front-panel key. User must make sure the 7720 is in the desired state before executing this command and essential delay time generated to ensure the key command is executed without loss of information prior to sending a further command.

Where n = 1	Number key 1
2	Number key 2
3	Number key 3
4	Number key 4
5	Number key 5
6	Number key 6
7	Number key 7
8	Number key 8
9	Number key 9
0	Number key 0
.	Dot key
B	Backspace
U	Up arrow
D	Down arrow
l	Left arrow
R	Right arrow
E	Enter
T	Test
E	Exit
N	Func
Y	Sys
L	Learn
P	Para
a	Function key 1
b	Function key 2
c	Function key 3
d	Function key 4
e	Function key 5
f	Function key 6

Test Step Number (S?)

Returns the number of the step that is currently being edited.

Trigger (T)

Trigger the 7720 and query the test result with waveform data returned.

Trigger (t)

Trigger the 7720 and query the test result without waveform data being returned.

7.2 Handler Port

7.2.1 Pin Assignment

A test is performed whenever IPC \emptyset and GND are shorted.

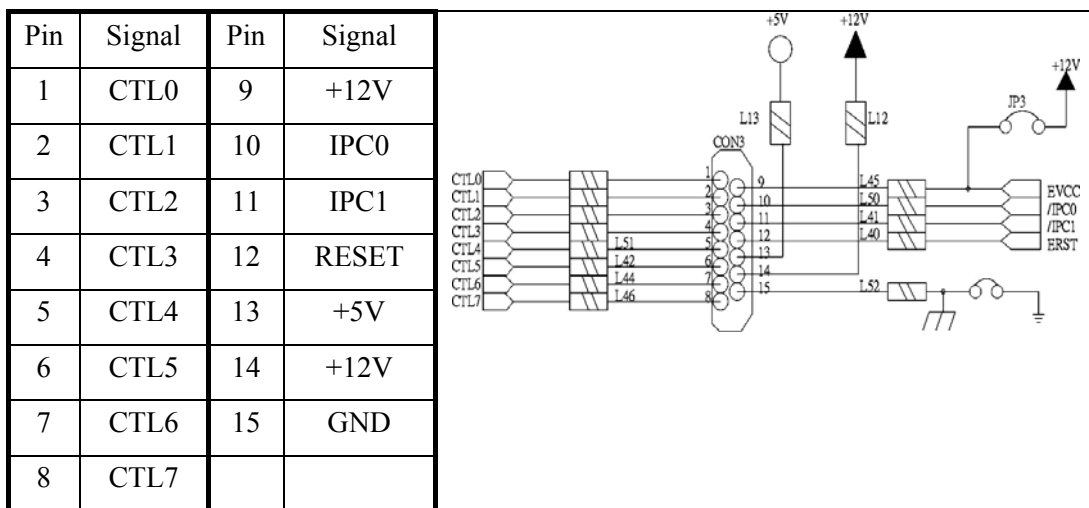

PIN	NAME	Description
1	CTRL1	PASS, to indicate the pass test result
2	CTRL2	FAIL, to indicate the fail test result
3	CTRL3	H.V. ON, to indicate the high voltage is applied
4	CTRL4	Testing, to indicate the test is in progress
5	CTRL5	Reserved
6	CTRL6	Reserved
7	CTRL7	Reserved
8	CTRL8	Reserved
9	+12V	12V DC output for user applications
10	IPC0	Test is performed whenever IPC \emptyset and GND are shorted.
11	IPC1	Reserved

12	RESET	System is reset whenever RESET and GND are shorted.
13	+5V	5V DC output for user applications
14	+12V	same as pin 9
15	GND	Ground

CTRL0 – CTRL3 are photo-coupled, they are grounded when active, floating when inactive.

7.2.2 Port Timing

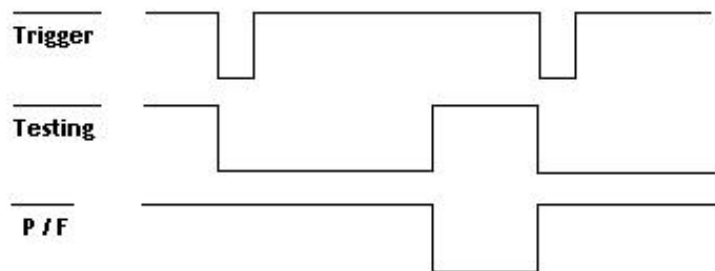

1. Trigger signal duration greater than 10mS.
2. PASS or FAIL is issued when all tests are finished and is not cleared until the next trigger pulse is received.

8. Theory of Operation

8.1 Applied Pulse

When a short high voltage pulse is applied to a perfect unloaded inductor a sine wave would be seen that continued to infinity without changing amplitude.

However, the perfect inductor does not exist and making a measurement will always apply a small load to the device under test. So what is actually seen is a sine wave with a decaying amplitude.

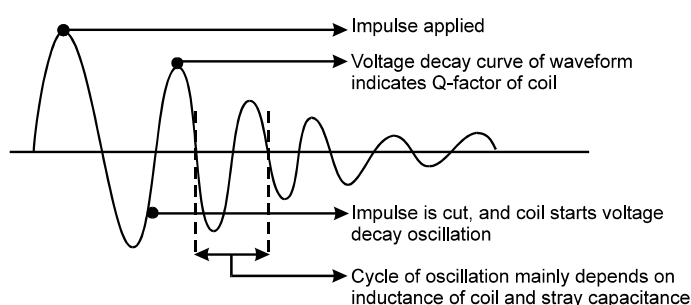

Figure 8-1 Theory of Operation

The waveform decay is related to the Q-factor of the coil: the higher the Q, the slower the rate of decay. The frequency of the waveform is related to the inductance and stray capacitance of the coil.

The Impulse Winding Tester 7720 allows the user to store a standard waveform produced from a known good 'golden' component sample. It will then compare this waveform against the waveform of the device under test.

8.2 Why Use Impulse Testing?

Impulse testing characterizes a winding in a way not possible on a conventional LCR meter. The short high voltage pulse will cause no damage to the device under test.

Comparing the waveform from a good device to that of the device under test will show differences in the number of turns, changes in the core material, shorted turns and corona discharge (damage to the winding).

The differences are shown as a waveform that decays at a different rate, which would be indicated by the area under the curve. A waveform that is out of phase with the standard waveform would be indicated by differential area size, or a combination of both indicated by waveform comparison.

Corona discharge, indicated by a spike on the waveform, is normally present when a high voltage charge is applied across a wire (winding) that has some damage to the insulation.

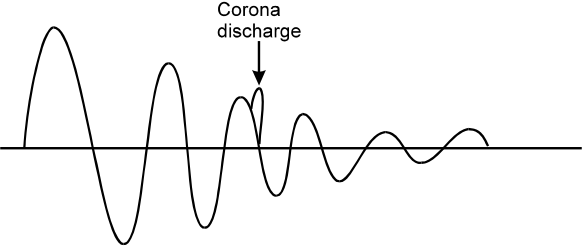

Figure 8-2 Corona Discharge

9. High Voltage Calibration & Test

WARNING!

HIGH VOLTAGE

This product is capable of having hazardous voltages (up to 10kV) on its terminals in normal use. Appropriate safety precautions should be taken.

High voltages are applied during calibration. Double check connections before calibration and test.

DO NOT TOUCH TEST LEAD OR VOLTAGE METER TERMINATIONS WHILE CALIBRATING THE INSTRUMENT.

CAUTION!

If the following procedure is not carried out correctly the output voltage may be set incorrectly, which could cause incorrect reading and/or damage to the device under test. Consult Microtest, before calibration, if the unit is suspected of being faulty.

9.1 High Voltage Calibration

To calibrate each output range voltage levels, select the FUNCTION menu using the **Func** key. Select High Voltage Calibration by pressing **Enter** when the **H/V CAL.** option is highlighted. Use the **▲** and **▼** navigation keys to select the required option or press the alphanumeric **3** key.

The 7720 will require a password before the calibration values can be adjusted.

To change voltage levels use the **▲** and **▼** navigation keys to select each nominal voltage level in turn. Once selected, the actual output will be displayed in the READING column. To adjust the voltage use the UP and DOWN soft keys until the value displayed is as close as possible to the nominal voltage selected.

Repeat this process for each nominal voltage level. When completed, press the DONE soft key.

If the EXIT is pressed any changes to the nominal voltage levels will not be saved.

Note

The H.V. output may be monitored using an external High Voltage meter (input resistance $\geq 1G\Omega$). Connect the meter probe to "H.V. CAL." and "RETURN" to measure the high voltage.

9.2 High Voltage Test

To check the output voltage at each available voltage step, select the FUNCTION menu using the **Func** key. Select the high voltage test by pressing **Enter** when the **H/V TEST** option is highlighted. Use the **▲** and **▼** navigation keys to select the required option or press the alphanumeric 4 key.

Turn the voltage on using the ON soft key: the unit will display the output voltage. Use the UP or DOWN soft keys to step through the voltages monitoring the displayed reading.

Note

The H.V. output may be monitored using an external High Voltage meter (input resistance $\geq 1\text{G}\Omega$). Connect the meter probe to “H.V. CAL.” and “RETURN” to measure the high voltage.

10. Specification

10.1 Measurement Ports

Two – 7700/7710

Eight – 7720

10.2 Advanced Functions

5000V testing voltage (7700/7720)

10000V testing voltage (7710)

Auto Learning / Auto Testing

Test Result Statistics and Analysis

System Self Diagnostic

Password Management

10.3 Testing Functions

Waveform Area

Waveform Area Changes

Corona -High Voltage Arching (Flutter)

Waveform Comparison

10.4 Voltage Pulse

7700/7720 Programmable 500~5000V $\pm 2\%$

7710 Programmable 500~10000V $\pm 2\%$

10.5 Measuring Time

50ms

10.6 Waveform Resolution

High Speed A/D Conversion

Maximum Sampling Time : 10ns

Maximum Sample size of 8192 Bytes

10.7 Display/Audio

320 x 240 LCD Display

Pass/Fail Red-Green LED and on Screen

Action Feedback Beep

10.8 Interface

RS-232

Printer Port

Remote Port

GPIB Port (Reserved)

10.9 Memory

Flash Memory

Store up to 100 sets of Wave Information

10.10 Power Supply

115/230 Vac Switchable $\pm 10\%$ 60/50Hz

10.11 Accessories

2 connection cables (7700/7710)

8 connection cables (7720)

Remote Connection Cable

Power Cord

User's Manual

10.12 Thermo/Humidity

0°C ~ 40°C

RH \leq 75%

10.13 Size

440mm x 145mm x 540mm (W x H x D)

10.14 Weight

About 13Kgs (accessories not included)

10.15 Options

/M2

Stores 200 sets of Waveforms

/M4

Stores 400 sets of Waveforms

11. Maintenance, Support and Services

11.1 Guarantee

The equipment supplied by is guaranteed against defective material and faulty manufacture for a period of twelve months from the date of dispatch. In the case of materials or components employed in the equipment but not manufactured by us, we allow the customer the period of any guarantee extended to us.

The equipment has been carefully inspected and submitted to comprehensive tests at the factory prior to dispatch. If, within the guarantee period, any defect is discovered in the equipment in respect of material or workmanship and reasonably within our control, we undertake to make good the defect at our own expense subject to our standard conditions of sale. In exceptional circumstances and at the discretion of the service manager, a charge for labour and carriage costs incurred may be made.

Our responsibility is in all cases limited to the cost of making good the defect in the equipment itself. The guarantee does not extend to third parties, nor does it apply to defects caused by abnormal conditions of working, accident, misuse, neglect or wear and tear.

11.2 Maintenance

11.2.1 Cleaning

The body of the equipment can be cleaned with a damp lint-free cloth. Should it be required, weak detergents can be used. No water must enter the equipment. Do not attempt to wash down internal parts.

11.2.2 Safety Checks

Each year the equipment should be given a simple safety check.

Equipment required

25A ground bond tester (e.g. Megger PAT 2)

Insulation tester @ 500V DC (e.g. Megger BM 7)

Tests

- 1) **DISCONNECT THE INSTRUMENT FROM THE AC POWER SUPPLY!**
- 2) Inspect the unit and associated wiring for damage e.g. dents or missing parts which might impair the safety or function of the equipment. Look for any signs of overheating or evidence that objects might have entered the unit.
- 3) **Ground Bond:** Ensure that 25A DC can flow from exposed metal parts of the unit (not BNC connector outers) to ground with an impedance of less than 100mΩ.
- 4) **Insulation Test:** Connect the Live and Neutral of the power cable together and test the insulation between this point and the ground at 500V DC. Readings greater than 1MΩ are acceptable.

11.3 Support and Service

In the event of difficulty, or apparent circuit malfunction, it is advisable to contact the service department or your local sales engineer or agent (if overseas) for advice before attempting repairs.

For repairs and recalibration it is recommended that the complete instrument be returned to one of the following:

Microtest
14F-6, No.79, Hsin Tai Wu Road, Sec. 1,
Hsi-chih, Taipei 221, Taiwan, R.O.C.
Tel: +886-2-2698-3877
Fax: +886-2-2698-4089
Email: sales@microtest.com.tw

When returning the instrument please ensure adequate care is taken with packing and arrange insurance cover against transit damage or loss. If possible re-use the original packing box.