



HI-POT Tester

7630

User's Manual

Version: 1.2

Issued Date: March 2017

Copyright and Trademark

Do not attempt to reproduce any part of this publication or transmit it by any form or method, whether through electronic, mechanical, copying, recording or other means, without the prior written permission of Microtest Co., Ltd. We shall neither be subjected to any responsibilities or obligations for the information contained in this Manual nor bear damage responsibility resulting from the use of the information contained herein. All brands and trademark are the properties of Microtest Co., Ltd.

Microtest Co., Ltd. and its affiliates shall not be liable for the damage, losses or costs incurred due to the accidental use, misuse or abuse by the product buyer or the third party; or the unauthorized modification, repairs or change of the product; or the failure in following the operation and maintenance instructions established by Microtest.

The content and the product specifications shall be subject to change without further notice.

2015 @ Microtest Corporation. All rights reserved.

Table of Contents

1. Safety Instruction.....	1
1.1 Electrocution	1
1.2 Grounding.....	1
1.3 Power Source.....	1
1.4 Connecting the Tester Table to the High Voltage Output Terminal.....	2
1.5 Warm-up.....	2
1.6 External control unit	2
1.7 Machine failure.....	2
1.8 Ending the test.....	2
1.9 Installation, storage	3
1.10 Emergency treatment.....	3
2 General Summary	4
2.1 Package and Accessories	4
2.2 Front Panel.....	5
2.3 Rear Panel.....	6
3 Basic operation	7
3.1 Function block diagram.....	7
3.2 Standby screen.....	8
3.3 System settings (SYSTEM)	10
3.4 Function (FUNC).....	12
3.5 Specification setup 1 (SETUP)	14
3.6 Specification setup 2 (SETUP)	16
3.7 File management (FILE).....	18
4 Start testing	21
4.1 Before testing.....	21
4.2 Testing in progress.....	22
4.3 Ending a Test	23
4.4 Release determination results	24
5 Remote control I/O (REMOTE)	25
6 RS-232/USB device.....	28
6.1 RS- 232 interface	28
6.2 Command format.....	28
6.3 Connector.....	28

6.4	Connection cable and method.....	29
6.5	USB device interface	30
7	Remote Command	31
7.1	Instruction summary.....	31
7.2	Command description.....	33
Appendix 1	Error message	41

1. Safety Instruction

This instrument is designed according to EN61010-1 Specification. The main purpose of this Specification is to ensure that the instrument will be used in the laboratory or the factory safely; it is not suitable for outdoor applications, especially the moistened or dusty locations. Abnormal use of this instrument may cause the electrocution hazard. Before using this instrument, please read the descriptions of this Specification carefully to avoid causing accident due to incorrect or unintended use.

1.1 Electrocution

To prevent electrocution accident from occurring, it is suggested that the operator wear insulating rubber globes before working with the machine and then start the test-related activities.

1.2 Grounding

The back panel of the instrument is fitted with a safe ground terminal. Be sure to connect this ground terminal to the ground to prevent the operator from touching the housing as to cause the electrocution.

1.3 Power Source

Power that can be used with this tester is AC 100Vac~240Vac with a frequency range between 47Hz~63Hz; please confirm whether the input power voltage and frequency are within range before plugging in the power.

1.4 Connecting the Tester Table to the High Voltage Output Terminal

While the tester is off, connect the high voltage tester cables to the high voltage output terminal of the tester and make sure that there are no ruptures outside the cables and that the cables are not loose.

1.5 Warm-up

The instrument will operate normally upon starting the power. To achieve the specified accuracy, it is suggested warming up the instrument for over 15 minutes.

1.6 External control unit

This unit is able to execute the external control. For this purpose, please ensure that the operator is not touching the signal output end and the Test Piece to avoid causing hazard.

1.7 Machine failure

Stop using the instrument immediately when finding it is operating abnormally, such as significant difference is existed between the current displayed on the current meter and the design value; or the current is not supplied, but the overlapping current indicator remains illuminated continuously. In this case, please contact us or your dealer to provide technical support.

1.8 Ending the test

When not using the instrument, please shut off the Power Switch. To restart the Power Switch after being disconnected, please wait for few seconds; however,

do not execute consecutive on/off action of the power.

1.9 Installation, storage

Normal operating temperature and humidity scope of the instrument is 5°C~40°C and 80% RH respectively, and the instrument may act abnormally if exceeding such range. The storage temperature and humidity scope of the instrument is -20°C~ 70°C and 80% RH respectively. To achieve correct testing and to protect safety, do not install the instrument in the environment exposing to direct sunshine or high temperature, high humidity, frequency oscillation and rich dust.

1.10 Emergency treatment

Upon the occurrence of electrocution, burning of the Test Piece or the burning of Main Unit, please disconnect the Power Switch and remove the power cord plug immediately to avoid causing a hazard.

2 General Summary

In this chapter, we briefly introduce the characters, key features and specifications of 7630 Precision Hi-Pot Tester.

2.1 Package and Accessories

Standard accessories included in the 7630 hipot tester package should include the following items:

• HT-7630	X 1
• HV cables (red)	X 1
• Low voltage cables (black)	X 1
• Power Cord	X 1
• HT-7630 User's Manual CD	X 1
• Inter lock cable	X 1

2.2 Front Panel

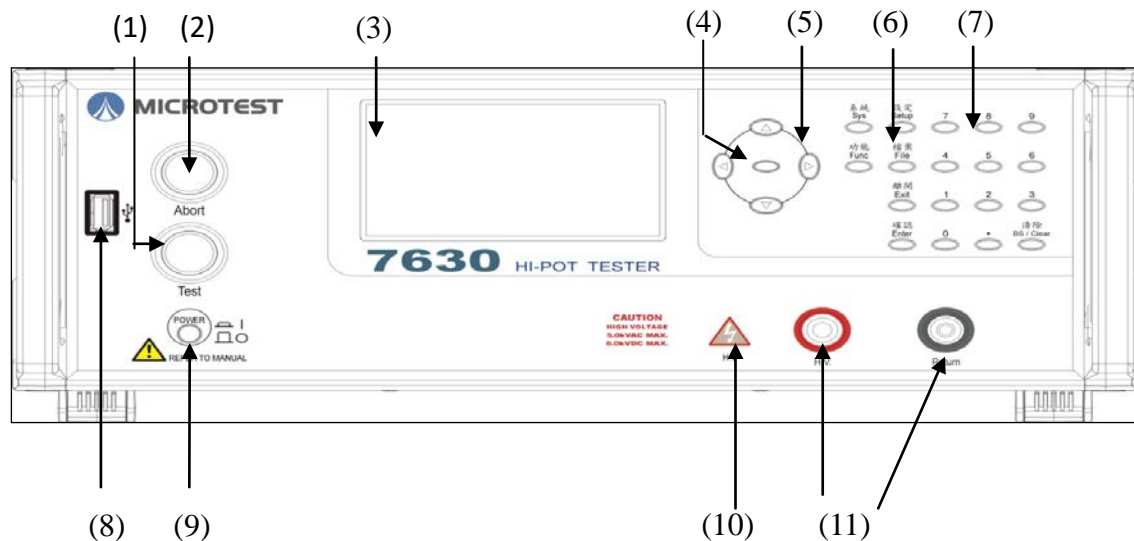

- (1) **Test key (with PASS light indicator):** Press to start testing the system in READY mode, it lights up after being tested successfully.
- (2) **Stop key (with FAIL light indicator):** Press to stop the test and close the high voltage output in test mode. It lights up when the test has failed. Press it to mute the alert buzzer.
- (3) **LCD color display:** Display settings and test results
- (4) **Software key:** These five software keys have functions as indicated by their screen, e.g. copy or delete. In case no functions are signed to a key, it displays a blank screen.
- (5) **Arrow key:** These keys move the cursor for editing. The center key functions the same as the OK function key.
- (6) **Function key:** Press to set up a function represented by the key which will be detailed later.
- (7) **Numeric key:** Press to edit numeric data.
- (8) **USB port:** Connect USB storage for setup file access and firmware updates.
Note: It supports FAT format only.
- (9) **Power switch: Power on or off the host.**
- (10) **High voltage output light indicator:** It lights up when there is a current output.
DO NOT touch the high voltage output port when this light is on as you may get shocked.
- (11) **High, low voltage output port:** Port for output test.

2.3 Rear Panel

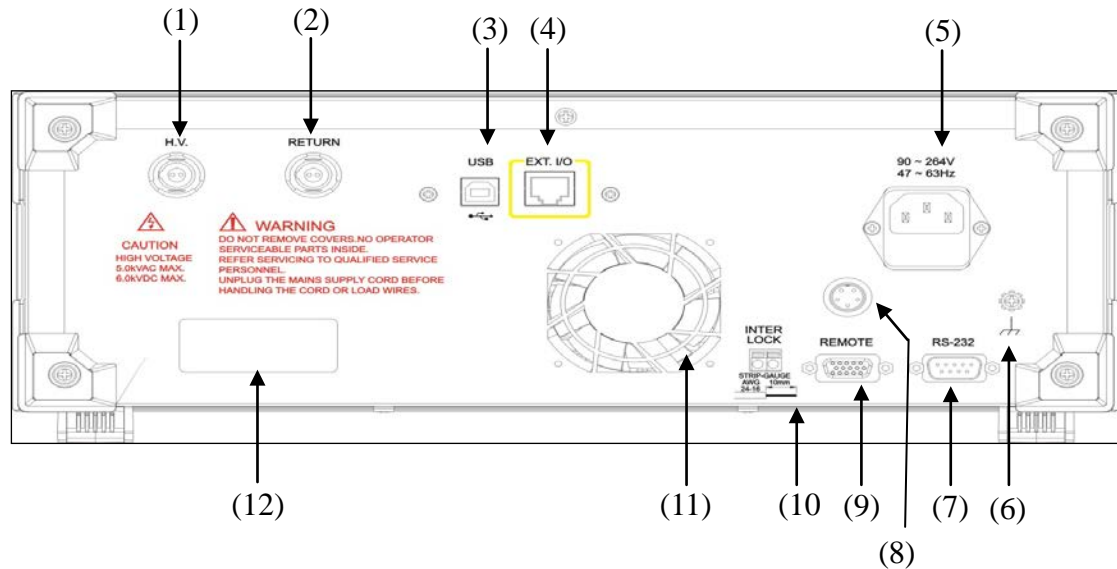

- (1) **High voltage output terminal:** Connection to the expansion box
- (2) **Low voltage output terminal:** Connection to the expansion box
- (3) **USB port:** Connection to the computer for controlling the machine with computer instructions
- (4) **Expansion box port:** Connect this port and an expansion box with a connection cable
- (5) **AC power socket:** AC power input connector with a 250V/3.15A fuse
- (6) **Iron casing terminal:** Ground your machine with this terminal for more steady device operation
- (7) **RS-232 connector:** Connect to the computer to control your machine with computer instructions
- (8) **High voltage tester port:** Connect the high voltage tester to this port
- (9) **Remote controller port:** Signal for external control including the determination and testing signal output or input of an external signal for test start and stop
- (10) **Inter Lock port:** High voltage current output safety switch. Short circuit both ends of this port during testing for the test voltage output. Opening the circuit of this port during testing will stop the test and prompt the message "INTER LOCK"
- (11) **Exhaust outlet:** Air exhaust for cooling
- (12) **Serial number sticker:** Indicates the serial number of your machine

3 Basic operation

3.1 Function block diagram

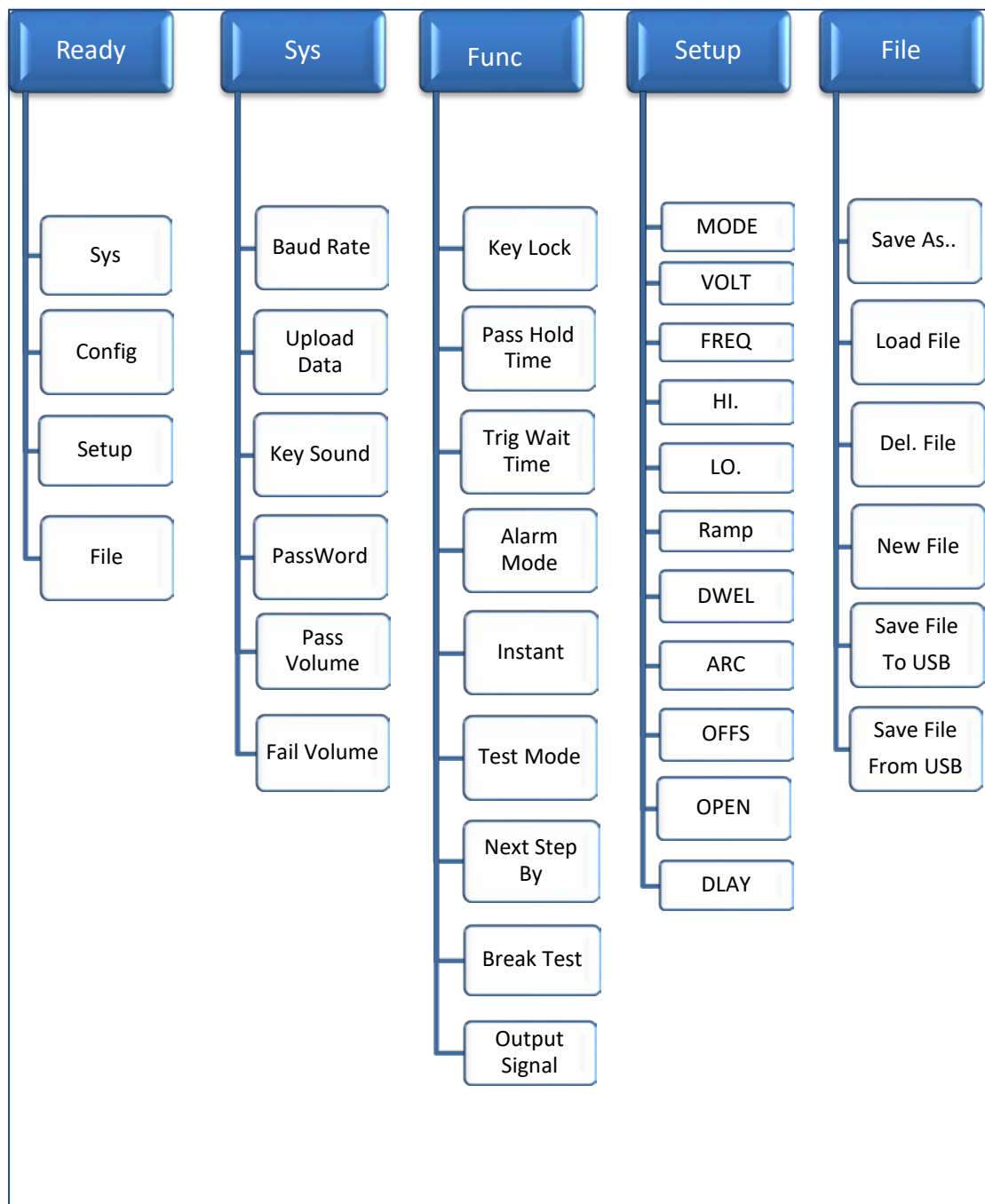

3.2 Standby screen

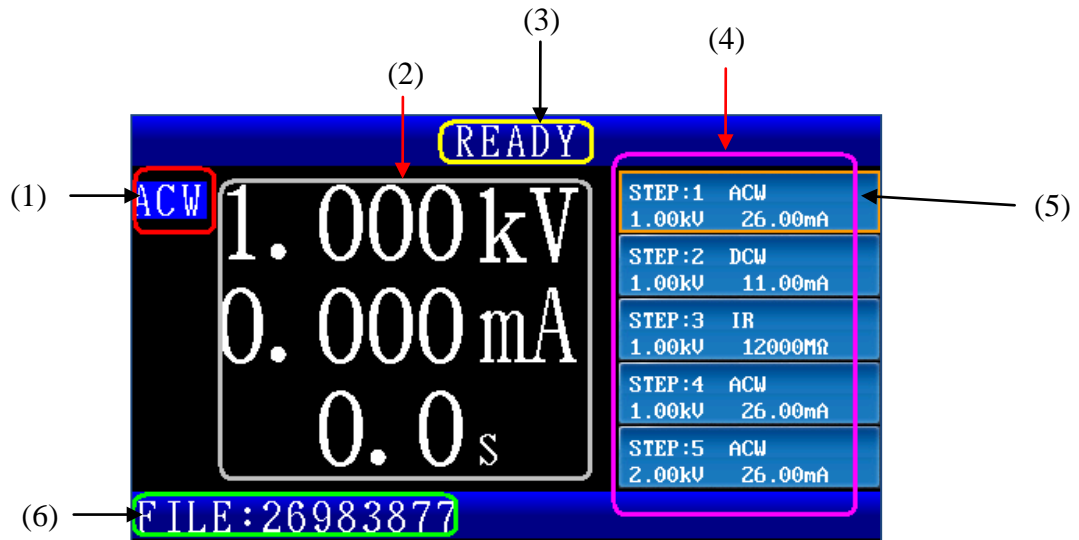

- (1) Display the current test mode: Message "ACW" for AC voltage testing, "DCW" for DC voltage testing, "IR" for insulation impedance testing
- (2) Readings of the voltage, current (resistance in IR mode), and test time of the measurement output port now. It displays the current voltage and test time settings if no test is running now.
- (3) Display the current status of your machine as illustrated in the table below:

Status display	Description
READY	Your machine is ready for testing now, press the TEST key to begin testing
TEST	Testing now
WAIT	The Trig Wait Time which can be set up in the CONFIG menu
WAIT KEY	Waiting for the trigger signal for the next test
PASS	Tested successfully (qualified goods)
Break Down	Leak current exceeds the maximum measurement
Arcing	Arc exceeds the upper limit
Lo-Limit	Measurement exceeds the lower limit
Hi-limit	Measurement exceeds the upper limit
FAIL	At least one step in a multi-step test failed
INTER-LOCK	High voltage safety lock on
VOLT-ERROR	Voltage output error
OPEN	Test wire disconnection error

- (4) Display the first five test steps of the current file
- (5) The orange color framed step is the one under testing (DUT) now along with its specifications displayed. You may select the desired step by moving the cursor to it with arrow key. Press the ENTER key to set up the test items.
- (6) Display the name of the current file. The name appended with an asterisk "*" suggests the file has been edited but not saved. In this case the current settings cannot be copied to a mobile storage device.

3.3 System settings (SYSTEM)

SYSTEM MENU		OPT
(1)	Baud Rate	115200
(2)	Upload Data	OFF
(3)	Key Sound	OFF
(4)	Password	Change
(5)	Pass Volume	3
(6)	Fail Volume	3

(1) Baud Rate: You may set up a transmission speed of RS-232 to 9600, 19200, 38400, 57600, or 115200. Please note that this needs to be aligned with the speed at the control end.

(2) Upload Data: Automatically uploads the test results. Available options include OFF, RS-232, FLASH and BOTH. When the function is set as RS-232, the machine will automatically respond the current status. The statuses include: The machine will return the POWER ON and START strings when the machine is turning on, and the machine will return the current test step and result when the test ends. For example 01,ACW,1.001e+03,7.169e-06,PASS; in which the data has a total of five fields that are separated by commas. The first field represents the test step number; the second field represents the test mode, which includes the seven types ACW, DCW, IR, CONTACT, ACW-P, DCW-P and IR-P. The third field represents the output voltage during the test, which is marked with a scientific symbol. The fourth field represents the electric current value during the test, which is marked with a scientific symbol (this field returns the resistance value if the test item is IR). The fifth field represents the test result, which includes PASS (good product), HI-Limit(exceeded the maximum limit set), Lo-LIMIT(lower than the minimum limit set), INTER-LOCK(high voltage safety lock enabled), ABORT(test interrupted), BREAKDOWN(breakdown point detected), ARCING(discharge detected), VOLT ERR(voltage output error), and OPEN(DUT connection error). If multi-step test is performed, the final judgement result will be added when the test is completed. When the function is set to FLASH, once the machine test has ended, it will automatically write the test result into the mobile storage device. Its format is the

same as the RS-232 contents. The data storage path is \7630\STAT\current test file name.csv. When the function is set as BOTH, both the actions described above will be performed. When the function is set as OFF, this function is disabled.

Note: When the RS-232 and FLASH functions are enabled, since it takes some time to transmit the data (differs according to the transmission rate set and mobile access device), therefore there will be some time delay for continuous or multi-step tests.

- (3) Key Sound: Switch the key sound on/off (the keyboard clicks after a key is pressed successfully).
- (4) Password: This is the password protecting the keyboard lock. When the latter is on you have to input the correct password to unlock the keyboard. You may change the password here. Its factory default value is 7630.
- (5) Pass Volume: Volume for qualified goods after testing. You can set the volume in 5 steps from 1 to 5 with 1 being the softest and 5 the loudest. You can mute the pass sound in the FUN mode.
- (6) Fail Volume: Volume for failed goods after testing. You can set the volume in 5 steps from 1 to 5 with 1 being the softest and 5 the loudest. You can mute the fail sound in the FUN mode.
- (7) OPT: When this symbol appears on the screen, press the software keys to adjust the option.

3.4 Function (FUNC)

FUNCTION MENU		OPT
Key Lock	OFF	
Pass Hold Time	Infinity	
Trig Wait Time	0.0s	
Alarm Mode	ALL	
Instant	OFF	
Test Mode	ALL	
Next Step By	AUTO	
Break Test	1 FAIL	
Output Signal	TOTAL	

- (1) **Key Lock:** Keyboard lock prevents the test conditions from changes by unexpected user operation. Once it is on, users can start and stop the test without changing any settings. To unlock the keyboard, input the password you set earlier. To change the password, please refer to the system setup steps given earlier.
- (2) **Pass Hold Time:** The Retaining time for the qualified goods message display. Your machine prompts the message “PASS” and the output signal at the remote control port once a product is tested as qualified. This function sets up a time span of message display and signal output with the options of 50mS, 100mS, 500mS, 1S, 2S, 5S and Infinity. The “Infinity” option keeps on displaying test results until the ABORT key is pressed.
- (3) **Trig Wait Time:** This is the time span after your machine enters the test page (the “WAIT” message prompts in the status column) by pressing the test key until there is a high voltage current output for the test. This is used to get the test jig triggered and positioned for testing.
- (4) **Alarm Mode:** The alert mode has the options of ALL (alert all), PASS (alert for qualified goods), FAIL (alert for failed goods), and OFF.
- (5) **Instant:** You have to press and hold the TEST key to run the test in this mode. Release the key and the test stops immediately.
- (6) **Test Mode:** You may run the test in a single- or multi-step mode. You may press the up and down arrow key in single-step mode to select the desired test step and get test results immediately. Your machine begins test with the first step in SETUP through to the last one in multi-step mode. Test results are determined by the subsequent settings.
- (7) **Next Step By:** In multi-step mode your machine runs the next step based on the

given trigger source after the first one has ended. With the option "AUTO", the test runs the next step automatically; "Trig", the next step, will run only after the TEST key is pressed. This item is available only when **Test Mode is set to the option ALL.**

(8) Break Test: In multi-step mode, your machine stops or continues the test based on the settings in this field in case the results are failed goods. With option "1 FAIL", the test stops immediately in case of failed goods; for "OFF", the test ends only after the last step is executed. This item is available only when **Test Mode is set to the option ALL.**

(9) Output Signal: In multi-step mode, your machine gives a results signal in case this is set to the option "EACH"; with the option "TOTAL" it gives the output signal "PASS" or "FAIL" only after the test has ended.

3.5 Specification setup 1 (SETUP)

STEP	1	2	3	
MODE	ACW	ACW	ACW	COPY
VOLT	1.00kV	1.00kV	1.00kV	DEL
FREQ	50Hz	50Hz	50Hz	
HI.	26.00mA	26.00mA	26.00mA	
LO.	0.00mA	0.00mA	0.00mA	
RAMP	0.1s	0.1s	0.1s	
DWEL	300s	1.0s	1.0s	
ARC	0	0	0	
OFFS	0.000mA	0.000mA	0.000mA	

- (1) **STEP:** Step ID. Each file can have up to 16 steps. Press the software key COPY to add the next step; press the software key DEL to delete the step where the cursor is positioned. Each file must have at least one step.
- (2) **MODE:** There are three test mode options: ACW, DCW, IR which you can select with a software key.
- (3) **VOLT:** Set up the test voltage by typing its value with a numeric key. The maximum voltage varies with the test mode for ACW: 5.0kV, DCW: 6kV, IR: 1kV. Their minimum values are all 0.1kV.
- (4) **FREQ:** You may opt for a test frequency of 50Hz or 60Hz.
- (5) **HI.:** This is the upper limit of measurement. In case test readings exceed this limit the test has failed and is ended immediately. This value varies with the test mode for ACW: 26mA, DCW: 11mA, IR: 1200MΩ. For IR tests with settings at 1200M, no upper limit will be judged.
- (6) **LO.:** This is the lower limit of measurement. In case test readings exceed this limit, the test has failed and is ended immediately. For settings at a value 0, no lower limit will be judged.
- (7) **Ramp:** This is the time span for the voltage to rise from 0 to the target value ranging from 10S to 0.1S.
- (8) **DWEL:** This is the time span for sustaining the test after the voltage reaches the given settings. For a setting of value 0, the test continues until the stop key is pressed or the test fails.
- (9) **ARC:** This item sets up arc sensitivity. The greater the value is, the less sensitive the arc detection is. Setting it to 0 will disable your machine from making any

judgment over the arc during the test.

- (10) **OFFS:** This item resets the test end to prevent the impact of the external jig on accuracy. It deducts the leak current by the jig in advance and displays the actual leak current of the DUT with the equation "measurement readings = actual measurement less reset value". This item has two options: Manual and auto. The first requires manual input of the leak current value. The second contains the following steps: Remove the DUT from your machine; point the cursor to the field OFFS and press the software key AUTO; your machine measures according to the given voltage statistics and prompts the results; the message "SAVE=ENTER" displays after the measurement operation is done; press the ENTER key to save the test value or the EXIT key to exit without saving it; the saved value will be deducted from each measurement to enable a more accurate test.

3.6 Specification setup2 (SETUP)

STEP	4	5	6	
OPEN	0	0	0	AUTO
DLAY	--- S	--- S	--- S	

(1) **OPEN:** Open circuit detection sensitivity. Poor connection of the high voltage test wire to the DUT may lead to a lower measurement current and invalid qualified product results in the voltage test. Once this function is enabled (with non-zero settings) your machine will measure the DUT's capacitance with low voltage for about 200ms before the high voltage test begins. In case the measured capacitance value is lower than the settings, the test wire may not be connected to the DUT properly and your machine will stop the test and prompt the message "OPEN".

You may set this in two options: Manual and auto. The first requires manual input of the given value. The second contains the following steps: Connect the DUT properly; point the cursor to the field OPEN and press the software key AUTO; your machine measures the given output channel and prompts the results; the message "SAVE=ENTER" displays after the measurement operation is done; press the ENTER key to save the test value or the EXIT key to exit without saving it.

Note: In case readings with or without connection to the DUT differ from each other in a range less than 20, then its capacitance is too small and may not be valid for using this method for an open circuit test.

(2) **DLAY:** This item is aimed at judging the delay time and is editable only in IR mode. For IR tests of the DUT with capacitance, this can be judged only after the capacitor is fully charged. The delay time starts counting only after voltage has reached the settings. Before that, your machine displays measurement without the upper and lower limit determination and enters judgment mode immediately after the delay time has expired. **As the delay time is contained in the test time,**

its settings must be lower than the latter.

- (3) **High voltage output time and results determination timing:** See the diagrams below for the results determination the timing after the TEST key is pressed by the user. Please note that in the IR delay and ascending time, no upper and lower limit will be determined while only the upper limit will be determined in the ascending time of the ACW and DCW modes.

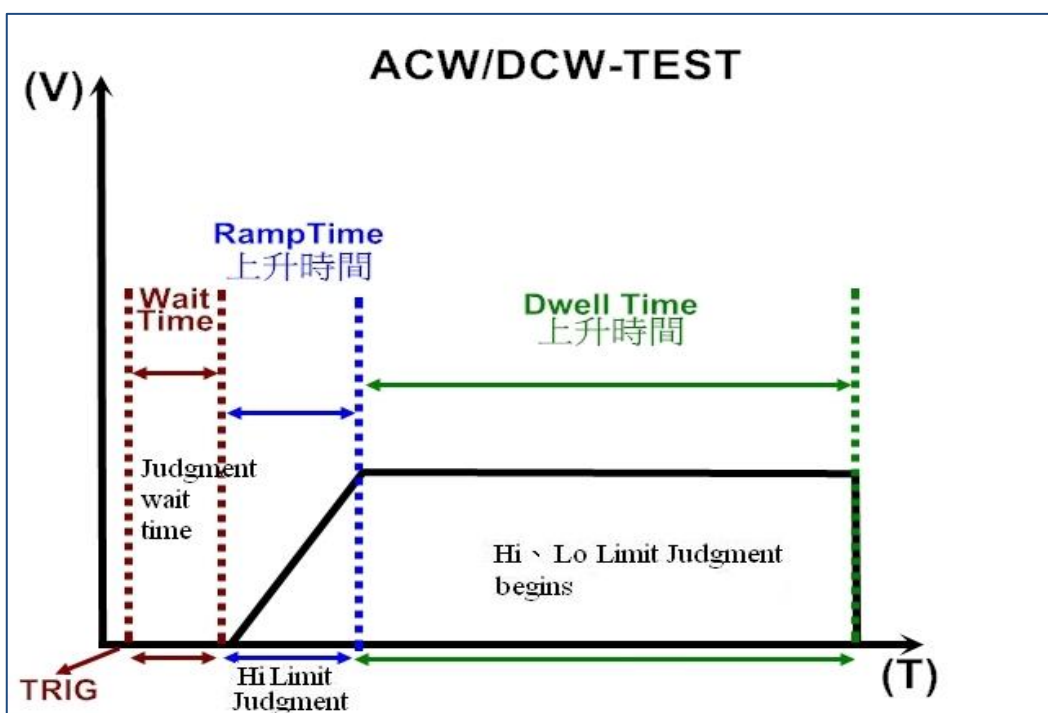
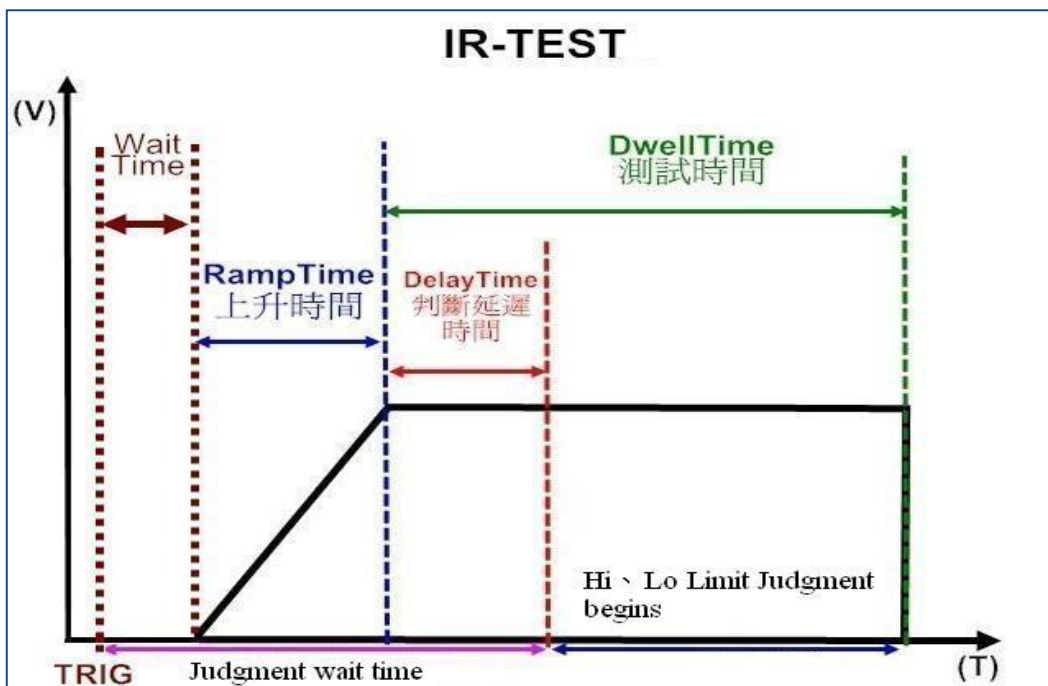

3.7 File management (FILE)

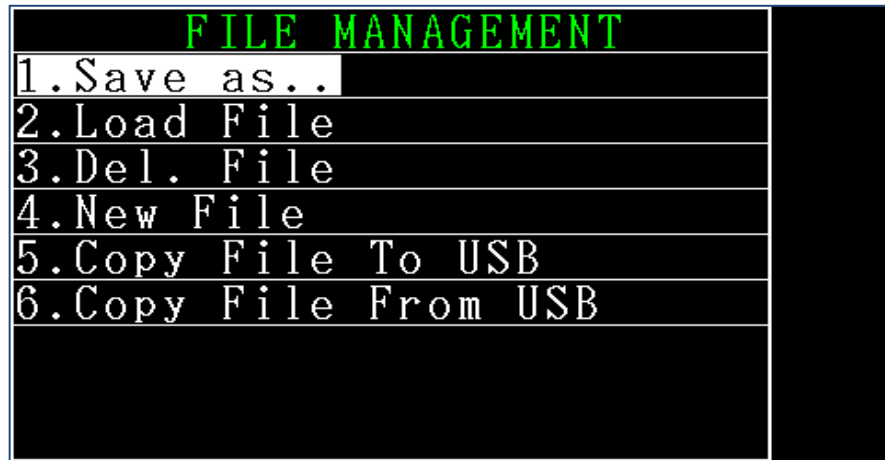

- (1) **Save As..:** This option saves the setup file with a new file name (**there can be up to 30 files saved in your machine**). The “file save” page displays the existing files in your machine. In case a USB drive is connected, a USB icon shows in the upper right corner of the page. You may press the software key to select saving a file in the USB drive or internal memory. You can type a new file name or select an existing file with the arrow key as shown in the figure below.

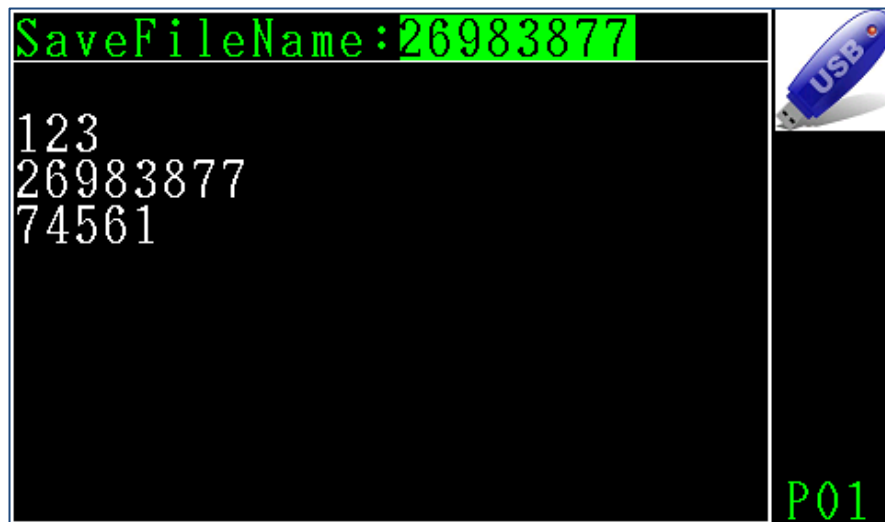

- (2) **Load File:** This item reads the existing file. The “file access” page displays the existing files in your machine. In case a USB drive is connected, a USB icon shows in the upper right corner of the page. You may press the software key to select retrieving a file in the USB drive or internal memory. You can type the file name or

select the existing file with the arrow key as shown in the diagram below. **Please note that all setting files are auto generated by your machine. DO NOT edit this data as the file may be damaged or the machine may run improperly.**

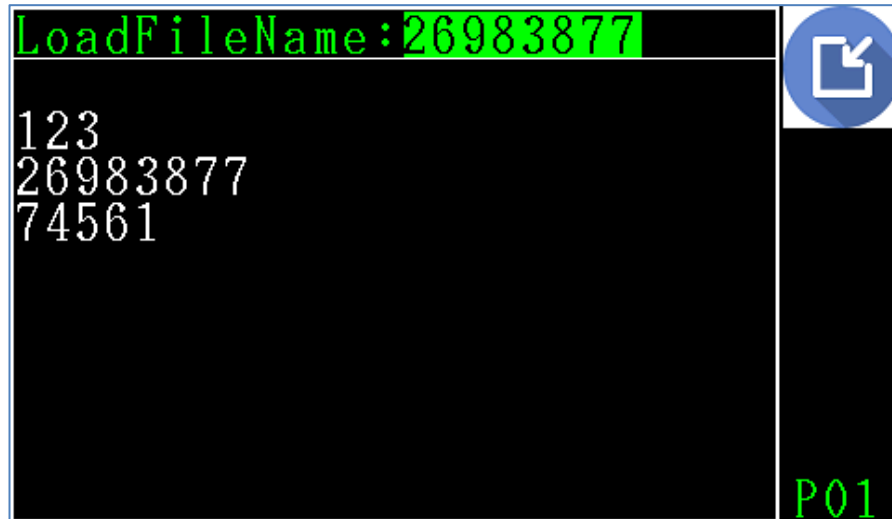

- (3) **Del File:** This item deletes the file in a manner similar to saving or retrieving it.
- (4) **New File:** This item initializes all existing files and creates a new one.
- (5) **Copy File to USB:** This item copies the existing setup files to a USB drive and overwrites any one in the latter with the same name. Enter this page to display the files existing in your machine, press the software key OPT to select one or more desired files, press the software key COPY to start copying the selected files. You may press the software key ALL to select all files shown in the current page for copying. Please note that the ALL option is valid for files on the current page only. For files on the next page, do the same to copy them as shown in the diagram below.

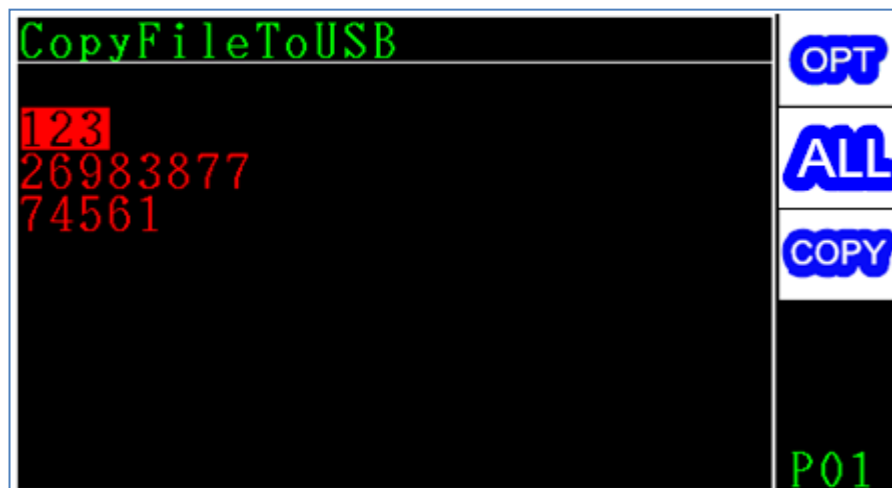

(6) **Copy File from USB:** This item copies the existing setup files to your machine from the USB drive and overwrites any one in the former with the same name. Enter this page to display the files existing in USB drive, press the software key OPT to select one or more desired files, press the software key COPY to start copying selected files. You may press the software key ALL to select all files shown in the current page for copying. Please note that the ALL option is valid for files on the current page only. For files on next page, do the same to copy them as shown in the diagram below.

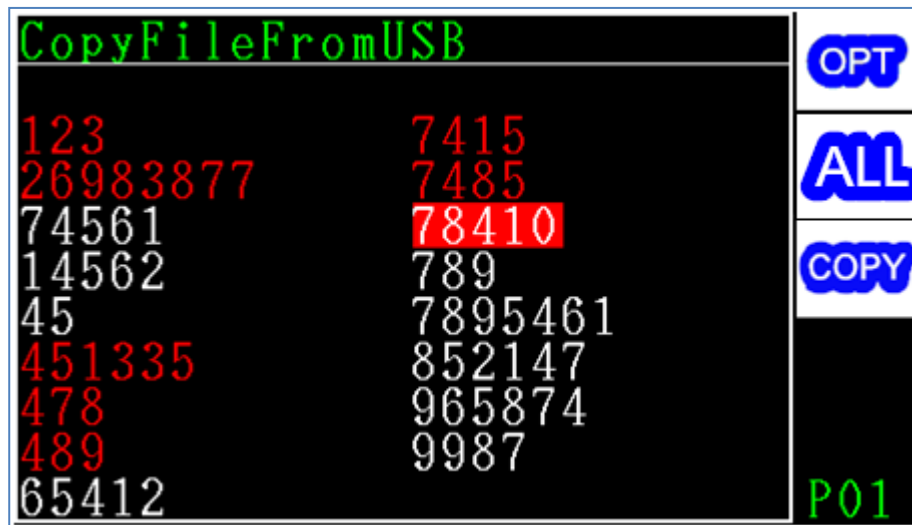

4 Start testing

4.1 Before testing

- (1) Validate specification setup
- (2) Validate the proper connection between your machine and DUT
- (3) Validate that the message READY is prompted
- (4) Press the TEST key to start testing

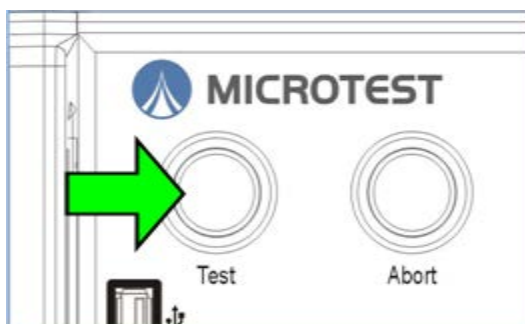
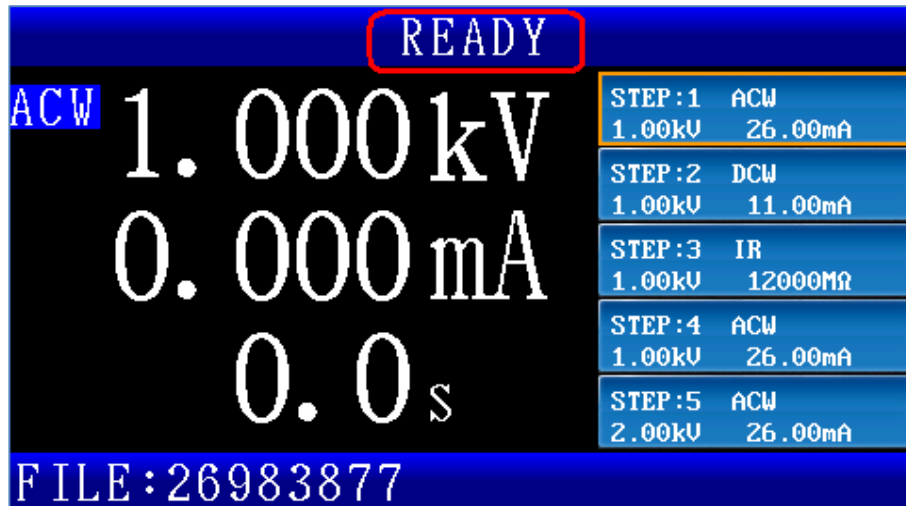

4.2 Testing in progress

- (1) The message TEST is shown in the message column
- (2) The high voltage output light indicator is ON in the front panel
- (3) Measure the output voltage and leak current
- (4) Test time counting. For tests lasting longer than 100 seconds, their integral portion is displayed while the decimal portion is hidden; if it is longer than 999 seconds then it stops counting the time while the number 999 remains flashing on screen.

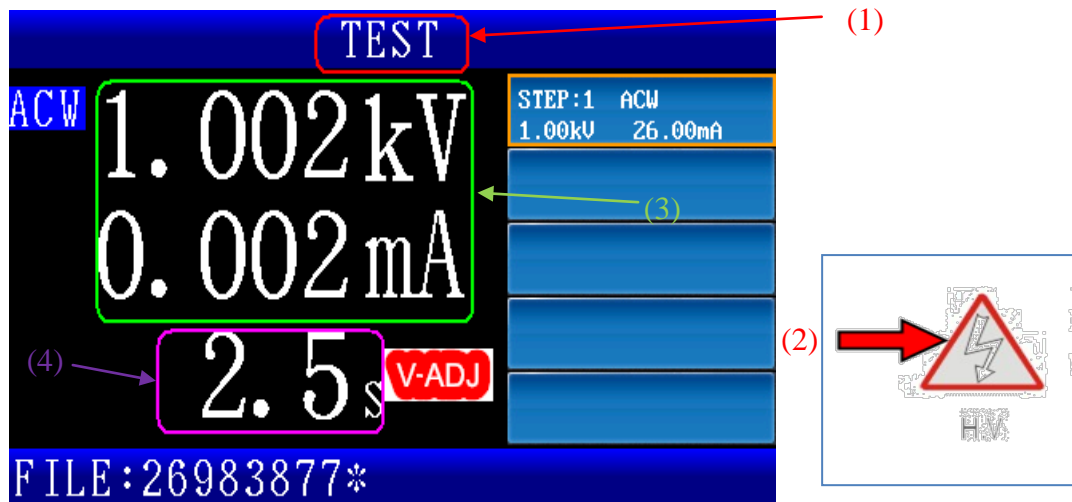

4.3 Ending a Test

- (1) Press the ABORT key to stop testing.



- (2) Current/resistance measurements over the upper limit (HI-LIMIT)
- (3) Current/resistance measurements below the lower limit (LO-LIMIT)
- (4) Leak current over the maximum measurement (Break Down)
- (5) Arc is over the settings (Arcing)
- (6) Output safety switch is enabled (Inter Lock)
- (7) Test DUT open circuit
- (8) Test time expired

The test ends in case of any of the above. The high voltage output light indicator turns off and the high voltage output closes after the test has ended. Tests ended because of the conditions 2-8 described earlier will prompt determination results.

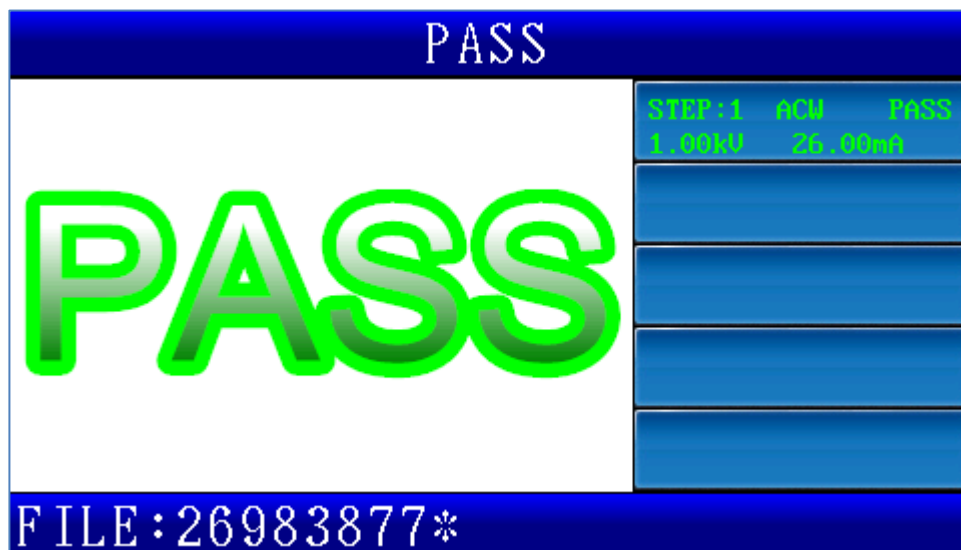

4.4 Release determination results

- (1) After the test time has expired, the PASS light(green) indicator turns on and the screen shows“PASS”. After the PASS HOLD time has expired, the page refreshes to READY status and the PASS light indicator turns off. In case PASS HOLD is set to Infinity, then you have to press the ABORT key to release the determination results display.
- (2) In case the test fails then a red FAIL light(red) indicator turns on and the screen shows“FAIL”. You have to press the ABORT key to release the determination results display.



5 Remote control I/O (REMOTE)

The rear panel of your machine comes with a remote control connector (REMOTE). Please connect the control wire to it to enable controlling your machine with an external signal. In cases like this, the test operator will not touch the high voltage output end to prevent personal injury.

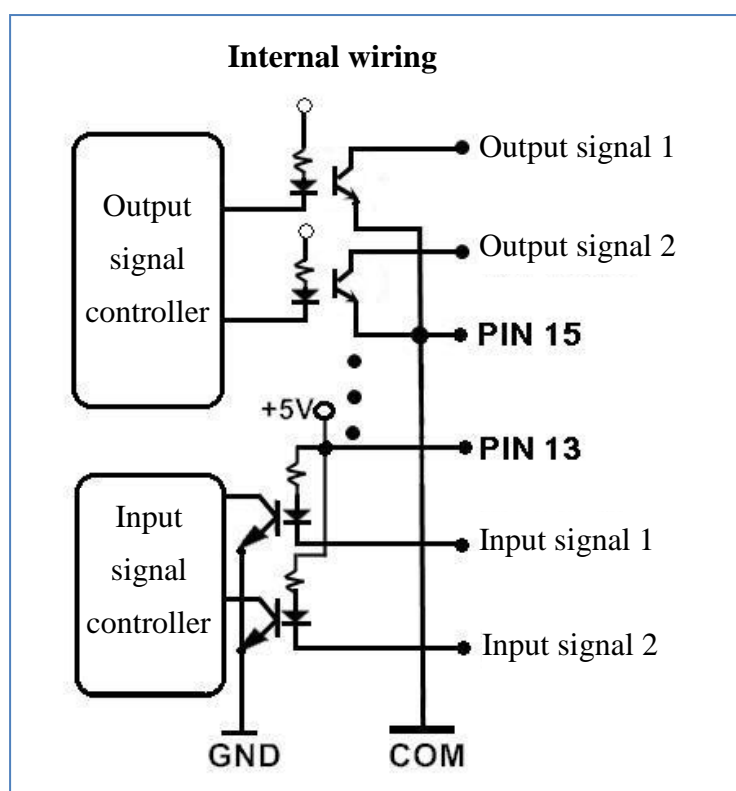
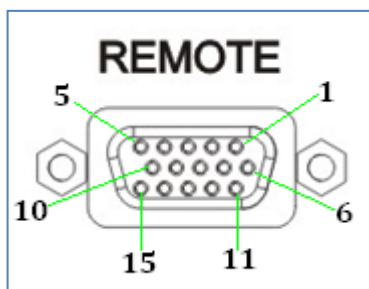

Pin	Name	I/O	Function
1	CTL1	O	Reserved
2	CTL2	O	Reserved
3	CTL3	O	Reserved
4	CTL4	O	Reserved
5	TESTING	O	Test in progress
6	PASS	O	Determination PASS

7	FAIL	O	Determination FAIL
8	HV-ON	O	High voltage output in progress
9	GND	---	Chassis Ground
10	TRIG	I	Test trigger
11	ABORT	I	Test abortion
12	RESET	I	Reset your machine
13	+5V	---	DC +5V output
14	+12V	---	DC +12Voutput
15	COM	---	Circuit common terminal

Use description:

PIN1-PIN8 is a collector open output without any voltage or signal. Current passing through the connector must be less than 50mA.

- (1) TRIG (Pin10): Functions the same as the TEST key in the front panel when short circuited with Pin15 (COM)
- (2) ABORT (Pin11): Functions the same as the ABORT key in the front panel when short circuited with Pin15 (COM)
- (3) PASS (Pin6): Conduct with Pin15 (COM) when the DUT is determined to PASS by your machine
- (4) FAIL (Pin7): Conduct with Pin15 (COM) when the DUT is determined to FAIL by your machine
- (5) TESTING (Pin5): Conduct with Pin15 (COM) when your machine is testing
- (6) H.V. ON: Conduct with Pin15 (COM) when your machine is outputting high voltage

Frequent uses:

1. (Input signal) Control your machine for testing by using a normal open switch relay

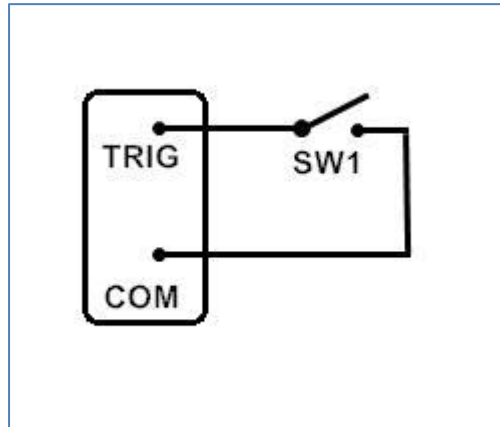

2. (Output signal) Control the relay with the output signal. Please connect the relay coil to a regulator diode for safer application

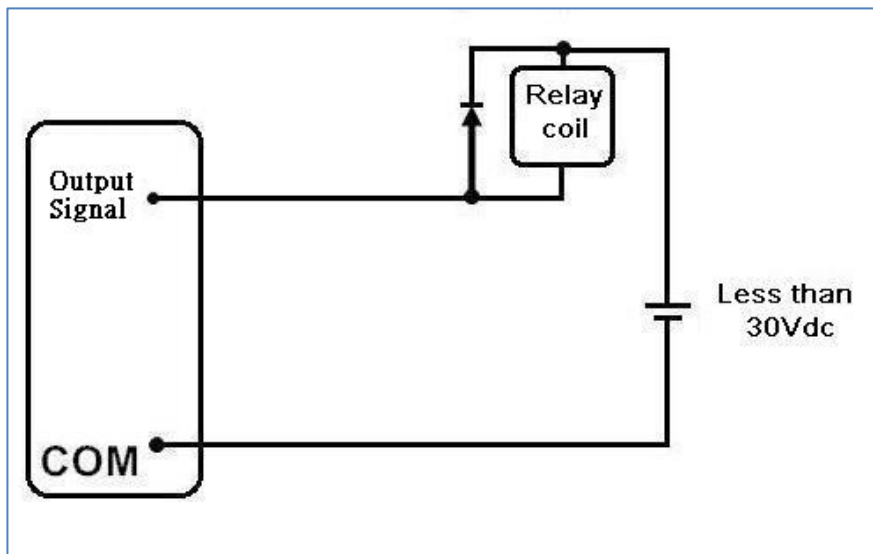

6 RS-232/USB device

6.1 RS- 232 interface

Baud Rate: Available options are 9600/19200/38400/57600/115200 and it can be set up in the System mode

Transmission bits: 1 initial bit, 8 data bits, 1 ending bit

6.2 Command format

The RS-232 interface function of your machine is exercised by a command string in ASCII code for remote control and setup. Each command string is composed of the command code and its parameters, two commands are connected with a semicolon “;”, and appended with an end code. There are two types of end code: LF(0x0a) and CR(0x0d)+LF(0x0a).

6.3 Connector

Your machine employs a 9-pin male connector with pin functions outlined in the table below:

Pin	Name	Description
1	CD	Reserved
2	RxD	Receive data
3	TxD	Transmit data
4	DTR	Reserved
5	GND	Ground point
6	DSR	Reserved
7	RTD	Reserved
8	CTS	Reserved
9	RI	Reserved

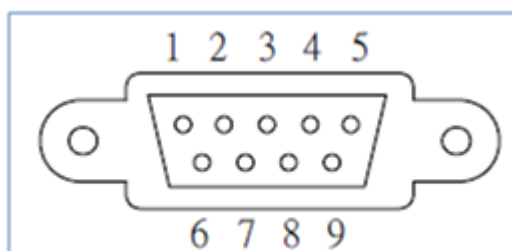

6.4 Connection cable and method

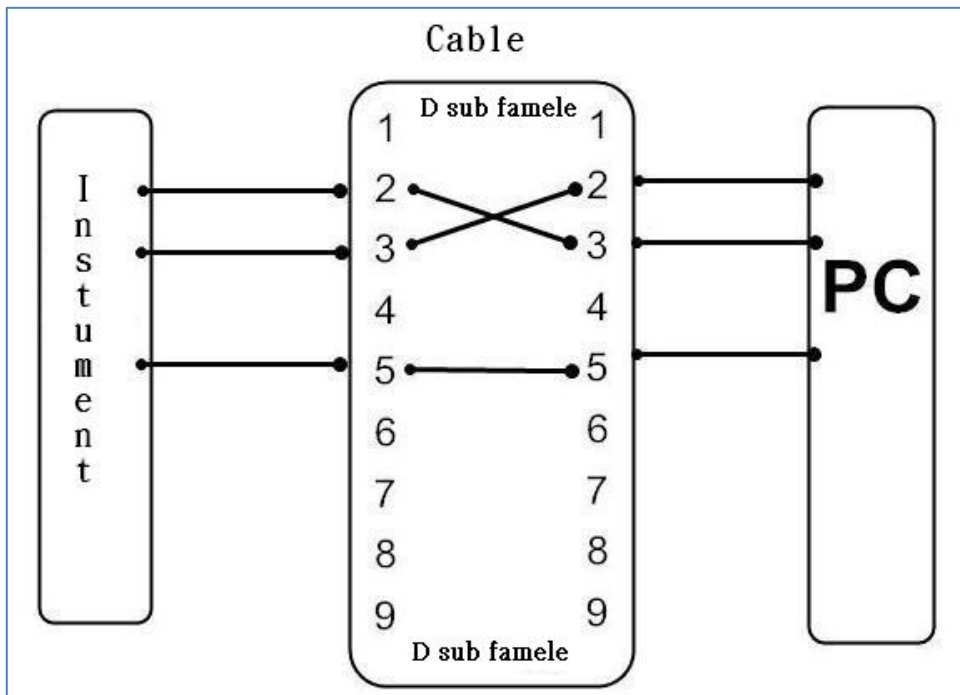

6.5 USB device interface

Interface I/O	USB Specification 2.0 Self-powered Transfer rate: MAX 12Mbps(Full Speed)
Instruction string end code	For receiving: LF or EOM For transmission: LF+EOM
Vendor ID	0x1FC9
Product ID	0x811D

7 Remote Command

7.1 Instruction summary

Common command

*CLS
 *IDN?
 *OPC
 *OPC?
 *OPT?
 *RCL
 *SAV

SCPI command

:CONFigure	:KLOCK	<ON , OFF, 1, 0>		
	:ALARm	<ALL,PASS, FAIL,OFF>		
	:PHOLd	<50ms,100ms,500ms,1s,2s,5s,INFinity>		
	:TGWAit	<NRf>		
	:TMODe	<SINGLE,MULTI>		
	:TMODe	:MULTi	:TSOURce	<AUTO,TRIG>
	:TMODe	:MULTi	:BREAK	<FAIL,OFF>
	:TMODe	:MULTi	:SIGNal	<EACH,TOTAL>
:EDIT	:STEP	<numeric>		
	:FUNCTion	<ACW,DCW,IR>		
	:VOLTage	<NRf>		
	:FREQuency	<NRf>		
	:HILimit	<NRf>		
	:LOLlimit	<NRf>		
	:RAMP	<NRf>		
	:DWELl	<NRf>		
	:CHANnel	:POSitive	<numeric>	
	:CHANnel	:NEGAtive	<numeric>	
	:CHANnel	:CLOSE	<numeric>	
	:ARC	<numeric>		
	:OFFSet	<NRf>		

	:OPEN	<NRf>		
	:IR	:DELAY	<NRf>	
	:STEP	:COUNT?		
	:STEP	:DELETE	<numeric>	
	:STEP	:ADD	<numeric>	
	:STEP	:CONDITION	<numeric>	
:MEASURE	:VOLTAGE?			
	:CURRENT?			
	:RESISTANCE?			
	:TIME?			
:OPERATION	:STEP	<numeric>		
	:FILE?			
:RESU?				
:STAR				
:STOP				
:SYSTEM	:AUREPLY	<ON , OFF, 1, 0>		
	:KYSOUND	<ON , OFF, 1, 0>		
	:ALARM	[:VOLUME]	:PASS	<numeric>
	:ALARM	[:VOLUME]	:FAIL	<numeric>
	:ERROR?			
:TEST	:ABORT			
	:EXECUTE			

7.2 Command description

Common command

Command	Function
*CLS	Clears all the registers
*IDN?	Read the basic device data including the manufacturer, model, serial number, firmware release and output in comma delimited format
*OPC	Operation completion command
*OPC?	Query operation completion command: Return value 1 if operation completed; otherwise return value 0
*OPT?	Query whether the device is optional
*RCL	Command for reading the machine's internal files with the parameter of the file name in ASCII code, e.g. command “*RCL 26983877” means reading the file with the name “26983877”
*SAV	Command for saving the current settings in a new file with the file name in ASCII code, e.g. command “*SAV 26984089” means saving current settings in file with name “26984089”

SCPI command

<p>: CONFigure: KLOCk<ON , OFF, 1, 0></p> <p>This command locks or unlocks the keyboard</p> <p>Example: CONF: KLOC ON</p> <p>Example description: Locks the keyboard</p> <p>Example: CONF: KLOC? Return value: 1 <enabling></p>
<p>: CONFigure: ALARm<ALL,PASS, FAIL,OFF></p> <p>This command sets up an alert mode</p> <p>Example: CONF: ALAR FAIL</p> <p>Example description: Alert for FAIL determination results</p> <p>Example: CONF: ALARm? Return value: FAIL <Alert for FAIL></p>
<p>: CONFigure: PHOLd<50ms,100ms,500ms,1s,2s,5s,INFINITY></p> <p>This command sets up the retaining time for PASS display</p> <p>Example: CONF: PHOL 100ms</p> <p>Example description: Set up PASS display time to 100mS</p> <p>Example: CONF: PHOLd? Return value: +1.00000E-01 <100ms></p>

<p>: CONFigure: TGWAit<NRF></p> <p>This command sets up the test wait time after a trigger</p> <p>Example: CONF: TGWA 500mS</p> <p>Example description: Set up wait time after trigger to 500mS</p> <p>Example: CONF: TGWA? Return value: +5.00000E-01 <500ms></p>
<p>: CONFigure: TMODE<SINGLE,MULTI></p> <p>This command sets up the test mode</p> <p>Example: CONF: TMOD MULTI</p> <p>Example description: Set up test mode to multi-step test</p> <p>Example: CONF: TMOD? Return value: MULTI <multi-step mode></p>
<p>: CONFigure: TMODE: MULTI: TSOURce<AUTO,TRIG></p> <p>This command sets up a trigger source between the steps of multi-step testing</p> <p>Example: CONF: TMOD: MULT: TSOU AUTO</p> <p>Example description: Set up multi-step test auto to proceed with the next step</p> <p>Example: :CONF: TMOD: MULT: TSOU? Return value: AUTO <auto proceed with the next step></p>
<p>: CONFigure: TMODE: MULTI: BREAK<FAIL,OFF></p> <p>This command sets up a test source abortion for multi-step tests</p> <p>Example: CONF: TMOD: MULT: BREA FAIL</p> <p>Example description: Set a multi-step test to stop when any one of its steps fails</p> <p>Example: CONF: TMOD: MULT: BREA? Return value: FAIL <stop when any one step failed></p>
<p>: CONFigure: TMODE: MULTI: SIGNal<EACH,TOTAL></p> <p>This command sets up a signal output method in multi-step testing</p> <p>Example: CONF: TMOD: MULT: SIGN TOTAL</p> <p>Example description: Set a multi-step test to output the overall determination signal after every step has run</p> <p>Example: CONF: TMOD: MULT: SIGN? Return value: TOTAL <output overall determination signal></p>
<p>: EDIT: STEP <numeric></p> <p>This command sets up the step for editing. The following “EDIT” string headed command setting up step is specified by the command, e.g. after setting step 1 to be edited, all the following voltages or current values will be set to step 1. To edit step 2, it is necessary to switch to step 2 first (: EDIT: STEP 2).</p>

<p>Example: EDIT: STEP 1</p> <p>Example description: Set to edit step 1</p> <p>Example: EDIT: STEP? Return value: 1 <step 1></p>
<p>: EDIT: : FUNCTion< ACW,DCW,IR ></p> <p>This command sets up the test items</p> <p>Example: EDIT: FUNC ACW</p> <p>Example description: Set the test item to ACW</p> <p>Example: EDIT: FUNC? Return value: ACW</p>
<p>: EDIT: VOLTage<NRf></p> <p>This command sets up the test voltage</p> <p>Example: EDIT: VOLT 1kV</p> <p>Example description: Set the test voltage to 1kV</p> <p>Example: EDIT: VOLT? Return value: +1.00000E+02 <1kV></p>
<p>: EDIT: FREQuency<NRf></p> <p>This command sets up the frequency of test AC current</p> <p>Example: EDIT: FREQ 50HZ</p> <p>Example description: Set the frequency of test AC current to 50Hz.</p> <p>Example: EDIT: ACW: FREQ? Return value: +5.00000E+01 <50Hz></p>
<p>: EDIT: HILlmit<NRf></p> <p>This command sets up the upper determination limit</p> <p>Example: EDIT: HILI 1mA</p> <p>Example description: Set the upper determination limit to 1mA</p> <p>Example: EDIT: HILI? Return value: +1.00000E-03 <1mA></p>
<p>: EDIT: LOLlmit<NRf></p> <p>This command sets up the lower determination limit</p> <p>Example: EDIT: LOLI 0.5mA</p> <p>Example description: Set the lower determination limit to 0.5mA</p> <p>Example: EDIT: LOLI? Return value: +5.00000E-04 <0.5mA></p>
<p>: EDIT: RAMP <NRf></p> <p>This command sets up the voltage rising time</p> <p>Example: EDIT: RAMP 0.5s</p> <p>Example description: Set the voltage rising time to 0.5s</p> <p>Example: EDIT: RAMP? Return value: +5.00000E-01 <0.5s></p>
<p>: EDIT: DWELl<NRf></p>

<p>This command sets up the test time</p> <p>Example: EDIT: DWEL 1s</p> <p>Example description: Set the test time to 1s</p> <p>Example: EDIT: DWEL? Return value: +1.00000E+00 <1s></p>
<p>: EDIT: CHANnel : POSitive< numeric ><Invalid for model 7630></p> <p>This command sets up the high voltage output channel</p> <p>Example: EDIT: CHAN: POSI 1,2,3,4</p> <p>Example description: Set the high voltage output channel to 1, 2, 3, 4</p> <p>Example: EDIT: CHAN: POSI? Return value: 1,2,3,4</p>
<p>: EDIT: CHANnel : NEGAtive< numeric ><Invalid for model 7630></p> <p>This command sets up the low voltage output channel</p> <p>Example: EDIT: CHAN: NEGA 5,6,7,8</p> <p>Example description: Set the low voltage output channel to 5, 6, 7, 8</p> <p>Example: EDIT: CHAN: NEGA? Return value: 5,6,7,8</p>
<p>: EDIT: CHANnel : CLOSe< numeric >< Invalid for model 7630></p> <p>This command sets up the closed channel (channels without any output)</p> <p>Example: EDIT: CHAN: CLOS 1,5</p> <p>Example description: Set the channel 1 and 5 close</p> <p>Example: EDIT: CHAN: CLOS? Return value: 1,5</p>
<p>: EDIT: ARC < numeric ></p> <p>This command detects the arc sensitivity settings</p> <p>Example: EDIT: ARC 5</p> <p>Example description: Set the arc sensitivity to 5</p> <p>Example: EDIT: ARC? Return value: 5</p>
<p>: EDIT: OFFSet<NRf></p> <p>This command sets up the reset deduction value</p> <p>Example: EDIT: OFFS 0.002mA</p> <p>Example description: Set up the reset deduction value to 0.002mA</p> <p>Example: EDIT: OFFS? Return value: +2.00000E-06 <0.002mA></p>
<p>:EDIT: OPEN <NRf></p> <p>This command sets the sensitivity for open circuit detection</p> <p>Example: EDIT: OPEN 200</p> <p>Example description: Sets the open circuit detection sensitivity to 200</p> <p>Example: EDIT: OPEN?Return data: +2.00000E+2 <200></p>

<p>: EDIT: IR: DELAY<NRF></p> <p>This command sets up the IR delay determination time</p> <p>Example: EDIT: IR: DELA 0.1s</p> <p>Example description: Set up the IR delay determination time to 0.1S</p> <p>Example: EDIT: IR: DELA? Return value: +1.00000E-01 <0.1s></p>
<p>: EDIT: STEP: COUNT?</p> <p>This command queries the number of test steps</p> <p>Example: EDIT: STEP: COUN? Return value: 2 <this file contains 2 steps></p>
<p>: EDIT: STEP: DEL < numeric ></p> <p>This command deletes a test step</p> <p>Example: EDIT: STEP: DEL 2</p> <p>Example description: Delete test step STEP2</p>
<p>: EDIT: STEP: ADD < numeric ></p> <p>This command adds a test step</p> <p>Example: EDIT: STEP: ADD 2</p> <p>Example description: Add test step STEP2</p>
<p>: EDIT: STEP: CONDition? < numeric ></p> <p>This command queries the test step conditions</p> <p>Example: EDIT: STEP: COND? 2 Example description: Query test conditions of step 2</p> <p>Return value: ACW,1.00kV,50HZ,26.00mA, 0.00mA, 0.1s, 1.0s,0, 0.00mA,OFF.</p> <p>Sequence of conditions: test item, voltage, frequency, upper limit, lower limit, rising time, test time, arc sensitivity, reset deduction value, determination delay time</p>
<p>: MEASure: VOLTage?</p> <p>This command queries the current voltage measurement</p> <p>Example: MEAS: VOLT? Return value: +1.00000E+02 <1kV></p>
<p>: MEASure: CURREnt?</p> <p>This command queries the current measurement now</p> <p>Example: MEAS: CURR? Return value: +2.00000E-06 <0.002mA></p>
<p>: MEASure: RESistance?</p> <p>This command queries the current resistance measurement</p> <p>Example: MEAS: RES? Return value: +1.20000E+10 <12G></p>
<p>: MEASure: TIME?</p> <p>This command queries the test time elapsed up to now</p> <p>Example: MEAS: TIME? Return value: +1.0000E+0 <1S></p>

<p>: OPERation: STEP <numeric></p> <p>This command selects the test step: desired test step for single-step test and the first step for multi-step test</p> <p>Example: OPER: STEP 2</p> <p>Example description: Select the test step STEP2</p> <p>: OPERation: STEP? Return value: 2 <2ndSTEP></p>																		
<p>OPERation:FILE?</p> <p>This command queries the current file name</p> <p>Example:OPER:FILE? Return data: 26983877 <file name is 26983877></p>																		
<p>: RESULT?</p> <p>This command queries the test results</p> <p>Example: RESU? Return value: 01,+9.01235E+00,+7.52562E-07,+1.19756E+07,2 with contents in the following sequence: test step ID, voltage measurement, current measurement, resistance measurement, determination results where determination results are predefined codes with the meanings defined in the table below:</p> <table border="1" data-bbox="531 1099 1294 1816"> <thead> <tr> <th>Code</th> <th>Description</th> </tr> </thead> <tbody> <tr> <td>1</td> <td>Test aborted</td> </tr> <tr> <td>2</td> <td>Determination PASS</td> </tr> <tr> <td>3</td> <td>Measurement value over upper limit (determination FAIL)</td> </tr> <tr> <td>4</td> <td>Measurement value below lower limit (determination FAIL)</td> </tr> <tr> <td>5</td> <td>Arc detection (determination FAIL)</td> </tr> <tr> <td>6</td> <td>Breaking point voltage (determination FAIL)</td> </tr> <tr> <td>7</td> <td>Voltage error (the difference between the measured voltage and the voltage set is too great)</td> </tr> <tr> <td>8</td> <td>Open circuit error</td> </tr> </tbody> </table>	Code	Description	1	Test aborted	2	Determination PASS	3	Measurement value over upper limit (determination FAIL)	4	Measurement value below lower limit (determination FAIL)	5	Arc detection (determination FAIL)	6	Breaking point voltage (determination FAIL)	7	Voltage error (the difference between the measured voltage and the voltage set is too great)	8	Open circuit error
Code	Description																	
1	Test aborted																	
2	Determination PASS																	
3	Measurement value over upper limit (determination FAIL)																	
4	Measurement value below lower limit (determination FAIL)																	
5	Arc detection (determination FAIL)																	
6	Breaking point voltage (determination FAIL)																	
7	Voltage error (the difference between the measured voltage and the voltage set is too great)																	
8	Open circuit error																	
<p>: START</p> <p>This command starts a test which functions the same as the TEST key in the front panel</p> <p>Example: STArt.</p>																		

<p>: STOP</p> <p>This command stops a test which functions the same as the ABORT key in the front panel</p> <p>Example: STOP.</p>
<p>: SYSTem: AUREply<ON , OFF, 1, 0></p> <p>This command sets up the auto reply function of RS-232</p> <p>Example: SYST: AURE ON</p> <p>Example description: Enable auto reply function of RS-232</p> <p>Example: SYST: AURE? Return value: ON</p>
<p>: SYSTem: KYSound<ON , OFF, 1, 0></p> <p>This command sets up the key sound</p> <p>Example: SYST: KYSO ON</p> <p>Example description: Enable key sound function</p> <p>Example: SYST: KYSO? Return value: ON</p>
<p>: SYSTem: ALARm [: VOLUme]: PASS < numeric></p> <p>This command sets up the volume of PASS alert</p> <p>Example: SYST: ALAR: PASS 1</p> <p>Example description: Set the volume of PASS alert to1</p> <p>Example: SYST: ALAR: PASS? Return value: 1</p>
<p>: SYSTem: ALARm [: VOLUme]: FAIL< numeric></p> <p>This command sets up the volume of FAIL alert</p> <p>Example: SYST: ALAR: FAIL 5</p> <p>Example description: Set the volume of FAIL alert to5</p> <p>Example: SYST: ALAR: FAIL? Return value: 5</p>
<p>:SYSTem:ERROr?</p> <p>This command queries the error messages queued</p> <p>Please refer to Appendix 1 for the returned error message</p> <p>Example: SYST:ERRO? Return data:0,"No error" means there are no error messages in queue</p>
<p>: TEST: EXECute</p> <p>This command starts test which functions the same as the TEST key in front panel</p> <p>Example: TEST: EXEC</p>
<p>: TEST: ABORt</p> <p>This command stops a test which functions the same as the ABORT key in the front</p>

panel

Example: TEST: ABOR

Appendix 1 Error message

-100	Command error	Command error
-102	Syntax error	Syntax error
-103	Invalid separator	Invalid separator found in the command string
-108	Parameter not allowed	Received parameter that is not allowed
-109	Missing parameter	Missing parameter
-112	Program mnemonic too long	The program mnemonic exceeded 12 characters
-113	Undefined header(query a command only command or query command missing '?')	Undefined header received
-141	Invalid character data	Invalid character data received
-211	Trigger ignored	No acceptable triggering status
-221	Settings conflict	Conflict between command and device status and cannot be executed
-222	Data out of range	Parameter value exceeded allowable range
-223	Too much data	Command exceeded 64 characters
-292	Reference name does not exist	Specified name does not exist
-410	Query interrupted	Query interrupted. This is when a second query command was received when data was not yet returned for the first query command.
-420	Query unterminate	This is when the output queued data command was received but there is no data in the output queue