

Inherent Stability, Innate Accuracy

MICROTEST DCS-3100 Series Precision Power, Every Single Time

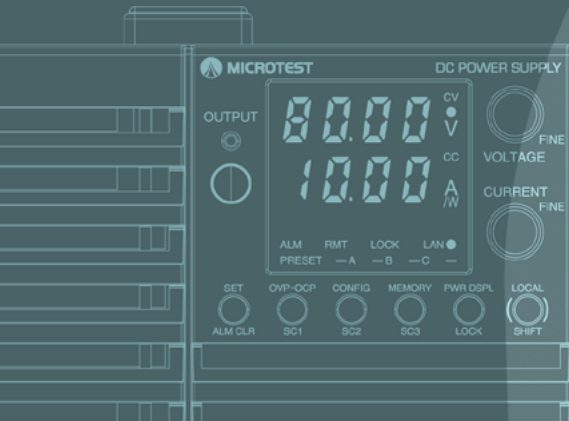

Compact Wide Range DC Power Supply DCS-3100 Series

400W Option



Power	Model	Voltage Range	Current Range	Output Power
400W	DCS3104A	0V~40V	0A~40A	400W
	DCS3104B	0V~80V	0A~20A	
	DCS3104C	0V~240V	0A~5A	
	DCS3104D	0V~650V	0A~1.85A	

1200W Option



Power	Model	Voltage Range	Current Range	Output Power
1200W	DCS3112A	0V~40V	0A~120A	1200W
	DCS3112B	0V~80V	0A~60A	
	DCS3112C	0V~240V	0A~15A	
	DCS3112D	0V~650V	0A~5.55A	

800W Option



Power	Model	Voltage Range	Current Range	Output Power
800W	DCS3108A	0V~40V	0A~80A	800W
	DCS3108B	0V~80V	0A~40A	
	DCS3108C	0V~240V	0A~10A	
	DCS3108D	0V~650V	0A~3.70A	

2000W Option



Power	Model	Voltage Range	Current Range	Output Power
2000W	DCS3120A	0V~40V	0A~200A	2000W
	DCS3120B	0V~80V	0A~100A	
	DCS3120C	0V~240V	0A~25.0A	
	DCS3120D	0V~650V	0A~9.25A	

Compact Wide Range DC Power Supply

DCS-3100 Series

Output power
400W/ 800W/ 1200W/ 2000W

Voltage Range
0V-40V/ 80V/ 240V/ 650V



MICROTEST DCS-3100 Series is a wide-range constant voltage/constant current DC power supply offering power outputs of 400 W, 800 W, 1200 W, and 2000 W, with voltage ranges up to 650 V, meeting the needs of production lines, R&D laboratories, and test system integrators.

DCS-3100 Series combines high stability, <1 ms fast transient response, advanced protection mechanisms, and LIST programmable output functionality. All models come standard with LAN, USB, and RS-232C interfaces, making them ideal for semiconductor ATE platforms, 12V/ 24V/ 48V battery simulation, capacitor and diode I-V characteristic/aging tests, power module verification, and automotive electronics applications.

Application

Semiconductor Power Devices | Optimized programmable DC power solutions for ATE systems

Batteries & BMS | Simulates 12V/24V/48V lithium or lead-acid battery discharge behavior

Capacitors & Diodes | Performs I-V characteristic analysis, aging, and 600V DC bias testing

DC-DC Modules | Provides DC input to converters, simulating real primary-side conditions

Features

- C.V/ C.C Priority Mode settable upon power-on to prevent voltage/current overshoot and ensure system stability.
- Features Programmable Sequencing and Synchronous Triggering for multi-unit coordinated operation, enhancing automated test efficiency.
- Built-in Front Panel 10A Output Terminals for use with safety plugs, ideal for R&D/ laboratory benchtop operation and measurement.
- In C.V. mode, the built-in Internal Resistance Simulation Function can be used to analyze the dynamic internal resistance characteristics of batteries and solar power sources.
- Bleeder Circuit ON/OFF Function for precise management of discharge behavior, eliminating the need for external protection components.
- Supports VMCB (Virtual Multi-Channel Bus) Architecture for single-PC control of multiple units (up to 31 units).
- Supports Single-Control Parallel Mode for high current output, providing a parallel power solution for EV and high-power module testing.
- Supports 2-Unit Series Mode (excluding D models).
- Supports External Signal Control Function.
- 3 Sets of Output Parameter Memory to store and quickly load settings for Voltage, Current, OVP, OCP, and UVL.
- Up to 3 Frequently Used System Settings can be registered to the front panel shortcut keys.
- Built-in WEB Server allows for remote control and monitoring using a PC/ mobile browser.
- Adopts an Industrial-Grade, High-Reliability "Tough" Design, ensuring stable operation at ambient temperatures up to 50°C .
- Standard Interfaces include LAN, USB, and RS-232C.

Specification

• 400W Model

DCS-3100 Series		DCS3104A	DCS3104B	DCS3104C	DCS3104D
AC input					
Input rating		100Vac~240Vac, 50Hz~60Hz, single phase			
Input voltage range		85Vac~265Vac			
Input frequency range		47Hz~63Hz			
Current (TYP.) *1	100 Vac	5.6A			
	200 Vac	2.8A			
Inrush current		25A or less			
Power (MAX.) *2		560VA			
Power factor (TYP.) *1		0.99 (input voltage: 100V) / 0.97 (input voltage: 200V)			
Efficiency (TYP.) *1		75%			
Continuous output time *2		20ms or more			

*1 At the rated output power for the rated output current.

*2 100 Vac, at the rated output power.

DCS-3100 Series		DCS3104A	DCS3104B	DCS3104C	DCS3104D	
Output						
Rating	Output voltage*1	40V	80V	240V	650V	
	Output current*1	40A	20A	5A	1.85A	
	Output power	400W				
Voltage	Maximum settable voltage*2	42V	84V	252V	682.5V	
	Setting accuracy	± (0.05 % of setting +0.05 % of rating)				
	Resolution		200mV	400mV	1000mV	2500mV
		Using FINE, OUT OFF	10mV	10mV	100mV	100mV
		Using FINE, OUT ON	1 mV	1 mV	10mV	10mV
		When Using Communication Interface	0.1mV	0.1mV	0.1mV	0.1mV
	Line regulation*3	±6mV	±10mV	±26mV	±67mV	
	Load regulation*4	±6mV	±10mV	±26mV	±67mV	
	Transient response*5	1ms or less	2ms or less	2ms or less	3ms or less	
	Ripple noise*6	p-p*7	50mV	50mV	100mV	300mV
		rms*8	5mV	5mV	20mV	50mV
	Rise time	At rated load	50ms or less		100ms or less	
		No load	50ms or less		100ms or less	
	Fall time*9	At rated load	50ms or less		150ms	250ms
		No load	500ms or less		1200ms	2000ms
Sense Compensation Voltage (Single Path, Max.)		1.5V	4V	5V	5V	
Temperature Coefficient*10		100ppm/ °C				
Current	Maximum settable current*2	42A	21A	5.25A	1.9425A	
	Setting accuracy*11	± (0.5% of setting +0.1% of rating)				
	Resolution		200mA	100mA	20mA	10mA
		Using FINE, OUT OFF	10mA	10mA	1mA	1mA
		Using FINE, OUT ON	1mA	1mA	0.1mA	0.1mA
		When Using Communication Interface	0.1mA	0.1mA	0.1mA	0.1mA
	Line regulation	±6mA	±4mA	±2.5mA	±2.2mA	
	Load regulation	±13mA	±9mA	±6mA	±5.4mA	
	Ripple noise* 12	80mA	40mA	12mA	6mA	
	Rise time(TYP.)	At rated load	50ms		100ms	
	Fall time(TYP.)	At rated load	50ms		100ms	
	Temperature Coefficient* 10		100ppm/ °C			
Programmable Internal Resistance (Max.)		1.000Ω	4.000Ω	36.00Ω	263.5Ω	

*1 The maximum output voltage and current are limited by the maximum output power.

*2 Can be limited to approximately 95% of the OVP/OCV setting point.

*3 Applicable under constant load conditions within the range of 85 Vac~135 Vac or 170 Vac~265 Vac.

*4 Variation when the load changes from no-load to rated load (rated power ÷ rated voltage) at the rated voltage, measured at the sensing point.

*5 Time required for the output voltage to recover within ±(0.1% + 10 mV) of the rated value. Load current change: 50%~100% of the maximum current at the set voltage.

*6 Measured using a JEITA Standard RC-9131C probe at rated current.

*7 Measurement bandwidth: 10 Hz~20 MHz.

*8 Measurement bandwidth: 10 Hz~1 MHz.

*9 When the divider function is set to "Normal Division."

*10 Temperature conditions 0°C~ 50°C

*11 Applicable within 1% to 100% of rated current. Values below 1% (down to 0%) are representative (0.1% of rated value).

*12 Under output voltage conditions of 10% to 100% of rated voltage and rated current. Calculation based on rated power ÷ rated current.

DCS-3100 Series		DCS3104A	DCS3104B	DCS3104C	DCS3104D
Display function					
Voltage display	Max display	99.99			999.9
	Display accuracy	± (0.2% of reading +5 digits)			
Current display	Max display	99.99			9.999
	Display accuracy	± (0.5% of reading +8 digits)			
Power display	Max display	9999			
PWR DSPL light will red	Display accuracy	Displays the product of voltage and current values			

• 800W Model

DCS-3100 Series		DCS3108A	DCS3108B	DCS3108C	DCS3108D
AC input					
Input rating		100Vac~240Vac, 50Hz~60Hz, single phase			
Input voltage range		85Vac~265Vac			
Input frequency range		47Hz~63Hz			
Current (TYP.) *1	100 Vac	11.2A			
	200 Vac	5.6A			
Inrush current		50A or less			
Power (MAX.) *2		1120VA			
Power factor (TYP.) *1		0.99 (input voltage: 100V) / 0.97 (input voltage: 200V)			
Efficiency (TYP.) *1		75%			
Continuous output time *2		20ms or more			

*1 At the rated output power for the rated output current.

*2 100 Vac, at the rated output power.

DCS-3100 Series		DCS3108A	DCS3108B	DCS3108C	DCS3108D	
Output						
Rating	Output voltage*1	40V	80V	240V	650V	
	Output current*1	80A	40A	10A	3.70A	
	Output power	800W				
Voltage	Maximum settable voltage*2	42V	84V	252V	682.5V	
	Setting accuracy	± (0.05 % of setting +0.05 % of rating)				
	Resolution		200mV	400mV	1000mV	2500mV
		Using FINE, OUT OFF	10mV	10mV	100mV	100mV
		Using FINE, OUT ON	1 mV	1 mV	10mV	10mV
		When Using Communication Interface	0.1mV	0.1mV	0.1mV	0.1mV
	Line regulation*3	±6mV	±10mV	±26mV	±67mV	
	Load regulation*4	±6mV	±10mV	±26mV	±67mV	
	Transient response*5	1ms or less	2ms or less	2ms or less	3ms or less	
	Ripple noise*6	p-p*7	50mV	50mV	100mV	300mV
		rms*8	5mV	5mV	20mV	50mV
	Rise time	At rated load	50ms or less		100ms or less	
		No load	50ms or less		100ms or less	
	Fall time*9	At rated load	50ms or less		150ms	250ms
		No load	500ms or less		1200ms	2000ms
Sense Compensation Voltage (Single Path, Max.)		1.5V	4V	5V	5V	
Temperature Coefficient*10		100ppm/ °C				
Current	Maximum settable current*2	84A	42A	10.5A	3.885A	
	Setting accuracy*11	± (0.5% of setting +0.1% of rating)				
	Resolution		400mA	200mA	40mA	20mA
		Using FINE, OUT OFF	10mA	10mA	10mA	1mA
		Using FINE, OUT ON	1mA	1mA	1mA	0.1mA
		When Using Communication Interface	0.1mA	0.1mA	0.1mA	0.1mA
	Line regulation	±10mA	±6mA	±3mA	±2.4mA	
	Load regulation	±21mA	±13mA	±7mA	±5.7mA	
	Ripple noise*12	160mA	80mA	24mA	12mA	
	Rise time (TYP.)	At rated load	50ms		100ms	
		At rated load	50ms		100ms	
	Temperature Coefficient*10		100ppm/ °C			
Programmable Internal Resistance (Max.)		0.500Ω	2.000Ω	18.00Ω	131.8Ω	

*1 The maximum output voltage and current are limited by the maximum output power.

*2 Can be limited to approximately 95% of the OVP/OCV setting point.

*3 Applicable under constant load conditions within the range of 85 Vac~135 Vac or 170 Vac~265 Vac.

*4 Variation when the load changes from no-load to rated load (rated power ÷ rated voltage) at the rated voltage, measured at the sensing point.

*5 Time required for the output voltage to recover within ±(0.1% + 10 mV) of the rated value. Load current change: 50%~100% of the maximum current at the set voltage.

*6 Measured using a JEITA Standard RC-9131C probe at rated current.

*7 Measurement bandwidth: 10 Hz~20 MHz.

*8 Measurement bandwidth: 10 Hz~1 MHz.

*9 When the divider function is set to "Normal Division."

*10 Temperature conditions 0°C~ 50°C

*11 Applicable within 1% to 100% of rated current. Values below 1% (down to 0%) are representative (0.1% of rated value).

*12 Under output voltage conditions of 10% to 100% of rated voltage and rated current. Calculation based on rated power ÷ rated current.

DCS-3100 Series		DCS3108A	DCS3108B	DCS3108C	DCS3108D
Display function					
Voltage display	Max display	99.99			999.9
	Display accuracy	± (0.2% of reading + 5 digits)			
Current display	Max display	99.99			9.999
	Display accuracy	± (0.5% of reading + 8 digits)			
Power display	Max display	9999			
PWR DSPL light will red	Display accuracy	Displays the product of voltage and current values			

• 1200W Model

DCS-3100 Series		DCS3112A	DCS3112B	DCS3112C	DCS3112D
AC input					
Input rating		100Vac~240Vac, 50Hz~60Hz, single phase			
Input voltage range		85Vac~265Vac			
Input frequency range		47Hz~63Hz			
Current (TYP.) *1	100 Vac	16.8A			
	200 Vac	8.4A			
Inrush current		75A or less			
Power (MAX.) *2		1680VA			
Power factor (TYP.) *1		0.99 (input voltage: 100V) / 0.97 (input voltage: 200V)			
Efficiency (TYP.) *1		75%			
Continuous output time *2		20ms or more			

*1 At the rated output power for the rated output current.

*2 100 Vac, at the rated output power.

DCS-3100 Series		DCS3112A	DCS3112B	DCS3112C	DCS3112D	
Output						
Rating	Output voltage*1	40V	80V	240V	650V	
	Output current*1	120A	60A	15A	5.55A	
	Output power	1200W				
Voltage	Maximum settable voltage*2	42V	84V	252V	682.5V	
	Setting accuracy	± (0.05 % of setting +0.05 % of rating)				
	Resolution		200mV	400mV	1000mV	2500mV
		Using FINE, OUT OFF	10mV	10mV	100mV	100mV
		Using FINE, OUT ON	1 mV	1 mV	10mV	10mV
		When Using Communication Interface	0.1mV	0.1mV	0.1mV	0.1mV
	Line regulation*3	±6mV	±10mV	±26mV	±67mV	
	Load regulation*4	±6mV	±10mV	±26mV	±67mV	
	Transient response*5	1ms or less	2ms or less	2ms or less	3ms or less	
	Ripple noise*6	p-p*7	50mV	50mV	100mV	300mV
		rms*8	5mV	5mV	20mV	50mV
	Rise time	At rated load	50ms or less		100ms or less	
		No load	50ms or less		100ms or less	
	Fall time*9	At rated load	50ms or less		150ms	250ms
		No load	500ms or less		1200ms	2000ms
Sense Compensation Voltage (Single Path, Max.)		1.5V	4V	5V	5V	
Temperature Coefficient*10		100ppm/ °C				
Current	Maximum settable current*2	126A	63A	15.75A	5.8275A	
	Setting accuracy*11	± (0.5% of setting +0.1% of rating)				
	Resolution		600mA	300mA	60mA	30mA
		Using FINE, OUT OFF	100mA	10mA	10mA	1mA
		Using FINE, OUT ON	10mA	1mA	1mA	0.1mA
		When Using Communication Interface	0.1mA	0.1mA	0.1mA	0.1mA
	Line regulation	±14mA	±8mA	±3.5mA	±2.6mA	
	Load regulation	±29mA	±17mA	±8mA	±6.1mA	
	Ripple noise*12	240mA	120mA	36mA	18mA	
	Rise time (TYP.)	At rated load	50ms		100ms	
		At rated load	50ms		100ms	
	Temperature Coefficient*10		100ppm/ °C			
Programmable Internal Resistance (Max.)		0.333Ω	1.333Ω	12.00Ω	87.84Ω	

*1 The maximum output voltage and current are limited by the maximum output power.

*2 Can be limited to approximately 95% of the OVP/OCV setting point.

*3 Applicable under constant load conditions within the range of 85 Vac~135 Vac or 170 Vac~265 Vac.

*4 Variation when the load changes from no-load to rated load (rated power ÷ rated voltage) at the rated voltage, measured at the sensing point.

*5 Time required for the output voltage to recover within ±(0.1% + 10 mV) of the rated value. Load current change: 50%~100% of the maximum current at the set voltage.

*6 Measured using a JEITA Standard RC-9131C probe at rated current.

*7 Measurement bandwidth: 10 Hz~20 MHz.

*8 Measurement bandwidth: 10 Hz~1 MHz.

*9 When the divider function is set to "Normal Division."

*10 Temperature conditions 0°C~ 50°C

*11 Applicable within 1% to 100% of rated current. Values below 1% (down to 0%) are representative (0.1% of rated value).

*12 Under output voltage conditions of 10% to 100% of rated voltage and rated current. Calculation based on rated power ÷ rated current.

DCS-3100 Series		DCS3112A	DCS3112B	DCS3112C	DCS3112D
Display function					
Voltage display	Max display	99.99		999.9	
	Display accuracy	± (0.2% of reading + 5 digits)			
Current display	Max display	999.9	99.99		9.999
	Display accuracy	± (0.5% of reading + 8 digits)			
Power display	Max display	9999			
PWR DSPL light will red	Display accuracy	Displays the product of voltage and current values			

• 2000W Model

DCS-3100 Series		DCS3120A	DCS3120B	DCS3120C	DCS3120D
AC input					
Input rating		100Vac~240Vac, 50Hz~60Hz, single phase			
Input voltage range		85Vac~265Vac			
Input frequency range		47Hz~63Hz			
Current (TYP.) *1	100 Vac	28A			
	200 Vac	14A			
Inrush current		125A or less			
Power (MAX.) *2		2800VA			
Power factor (TYP.) *1		0.99 (input voltage: 100V) / 0.97 (input voltage: 200V)			
Efficiency (TYP.) *1		75%			
Continuous output time *2		20ms or more			

*1 At the rated output power for the rated output current.

*2 100 Vac, at the rated output power.

DCS-3100 Series		DCS3120A	DCS3120B	DCS3120C	DCS3120D	
Output						
Rating	Output voltage*1	40V	80V	240V	650V	
	Output current*1	200A	100A	25A	9.25A	
	Output power	2000W				
Voltage	Maximum settable voltage*2	42V	84V	252V	682.5V	
	Setting accuracy	± (0.05 % of setting +0.05 % of rating)				
	Resolution		200mV	400mV	1000mV	2500mV
		Using FINE, OUT OFF	10mV	10mV	100mV	100mV
		Using FINE, OUT ON	1 mV	1 mV	10mV	10mV
		When Using Communication Interface	0.1mV	0.1mV	0.1mV	0.1mV
	Line regulation*3	±6mV	±10mV	±26mV	±67mV	
	Load regulation*4	±6mV	±10mV	±26mV	±67mV	
	Transient response*5	1ms or less	2ms or less	2ms or less	3ms or less	
	Ripple noise*6	p-p*7	50mV	70mV	120mV	350mV
		rms*8	5mV	5mV	20mV	50mV
	Rise time	At rated load	50ms or less		100ms or less	
		No load	50ms or less		100ms or less	
	Fall time*9	At rated load	50ms or less		150ms or less	250ms or less
No load		500ms or less		1200ms or less	2000ms or less	
Sense Compensation Voltage (Single Path, Max.)		1.5V	4V	5V	5V	
Temperature Coefficient*10		100ppm/ °C				
Current	Maximum settable current*2	210A	105A	26.25A	9.7125A	
	Setting accuracy*11	± (0.5% of setting +0.1% of rating)				
	Resolution		1000mA	500mA	100mA	50mA
		Using FINE, OUT OFF	100mA	100mA	10mA	10mA
		Using FINE, OUT ON	10mA	10mA	1mA	1mA
		When Using Communication Interface	0.1mA	0.1mA	0.1mA	0.1mA
	Line regulation	±22mA	±12mA	±4.5mA	±2.9mA	
	Load regulation	±45mA	±25mA	±10mA	±6.9mA	
	Ripple noise*12	400mA	200mA	60mA	30mA	
	Rise time (TYP.)	At rated load	50ms		100ms	
		At rated load	50ms		100ms	
	Temperature Coefficient*10		100ppm/ °C			
Programmable Internal Resistance (Max.)		0.200Ω	0.800Ω	7.200Ω	52.70Ω	

*1 The maximum output voltage and current are limited by the maximum output power.

*2 Can be limited to approximately 95% of the OVP/OCV setting point.

*3 Applicable under constant load conditions within the range of 85 Vac–135 Vac or 170 Vac–265 Vac.

*4 Variation when the load changes from no-load to rated load (rated power ÷ rated voltage) at the rated voltage, measured at the sensing point.

*5 Time required for the output voltage to recover within ±(0.1% + 10 mV) of the rated value. Load current change: 50%–100% of the maximum current at the set voltage.

*6 Measured using a JEITA Standard RC-9131C probe at rated current.

*7 Measurement bandwidth: 10 Hz–20 MHz.

*8 Measurement bandwidth: 10 Hz–1 MHz.

*9 When the divider function is set to "Normal Division."

*10 Temperature conditions 0°C~ 50°C

*11 Applicable within 1% to 100% of rated current. Values below 1% (down to 0%) are representative (0.1% of rated value).

*12 Under output voltage conditions of 10% to 100% of rated voltage and rated current. Calculation based on rated power ÷ rated current.

DCS-3100 Series		DCS3120A	DCS3120B	DCS3120C	DCS3120D
Display function					
Voltage display	Max display	99.99			999.9
	Display accuracy	± (0.2 % of reading + 5 digits)			
Current display	Max display	999.9			99.99
	Display accuracy	± (0.5 % of reading + 8 digits)			
Power display	Max display	9999			
PWR DSPL light will red	Display accuracy	Displays the product of voltage and current values			

•Applicable to the Entire Series

Model	400W Model	800W Model	1200W Model	2000W Model
Protection functions				
Overvoltage protection (OVP)	Output OFF *1, displays OVP, ALM ON			
Setting range	10% ~ 112% of rated output voltage			
Setting accuracy	± (1.5% of rating)			
Overcurrent protection (OCP)	Output OFF *1, displays OCP, ALM ON			
*2	Setting range 10% ~ 112% of rated output voltage			
	Setting accuracy ± (3% of rating)			
Front-panel output terminal overcurrent protection (FOCP)	Output OFF *1, displays FOCP, ALM ON			
*3	Value (fixed) 11 A (TYP.)			
Undervoltage limit (UVL)	Cannot Input a Voltage Value Below the Set Value.			
Setting range	0% ~ 105% of rated output voltage			
Overheat protection (OHP)	Output OFF, displays OHP, ALM ON			
Incorrect sensing connection protection (SENSE)	Output OFF, displays SENS, ALM ON			
Low AC input protection (AC-FAIL)	Output OFF *4, displays AC, ALM ON			
Shutdown (SD)	Output OFF *1, displays SD, ALM ON			
Power limit (POWER LIMIT)	ALM Blinking			
Value (fixed)	105% of rated output power			
Communication monitoring(WATCHDOG)	Output OFF, displays WDOG, ALM ON			
Master-slave parallel operation protection(PRL ALM)	Output OFF *1, displays PRL, ALM ON			

*1 Applies to the 2000W model when the output is turned OFF or the circuit breaker is tripped.
 *2 The peak discharge current generated by the product's internal capacitors during rapid load changes is not restricted by the protection mechanism.
 *3 This function is available on models with a maximum settable current over 11 A (when the OCP setting is lower than the FOCP value, the OCP setting takes priority).
 *4 Auto-restart function can be set to resume operation after the alarm condition is cleared.

Model	400W Model	800W Model	1200W Model	2000W Model
Other functions				
Output-on/ off delay	Setting range : 0.0s, 0.5s~99.9s *1 Setting resolution : 0.1s			
Soft start/ soft stop	Setting range : 0.0s, 0.5s~10.0s *1 Setting resolution : 0.1s			
Overcurrent protection (OCP) activation delay	Setting range : 0.0s~2.0s *1 Setting resolution : 0.1s			
Preset memory	A total of 3 sets of combined parameters (Voltage setting, Current setting, OVP setting, OCP setting, and UVL setting) can be stored.			
Key lock	All operations are disabled except for the OUTPUT button.			
System Configuration Shortcut Keys	3 system configuration settings can be registered to the SC1, SC2, and SC3 keys.			
Sequence	Number of programs: 1			
	Number of steps: 64			
	Repetitions (cycles):1~99998, Infinity			
	Number of section loops that can be configured:16			
	Section loop count:2~99998			
	Step Time:0.1s~100h (Applicable to step transition / illumination transition)			
Synchronized Operation	Synchronous voltage and current setting, Synchronous step restart for sequence program			
Master-slave parallel operation *2	3 Units, Including the Master Unit (same models)		2 Units, Including the Master Unit(same models)	
Series operation *3	2 units (same models)			
Multichannel (VMCB)	Main Unit to PC Connection	LAN, USB, RS232C		
	Slave Unit Connection	LAN		

*1 Factory default is 0.0 s.
 *2 Current difference between the master and slaves is 5% (TYP).
 *3 D type is excluded.

Model	400W Model	800W Model	1200W Model	2000W Model
Signal output and input				
Monitor signal output	Voltage monitor (VMON)	Selectable monitor voltage range : 0 V~5 V, or 0 V~10 V		
	Accuracy	2.5% of f.s.*1		
	Current monitor (IMON)	Selectable monitor voltage range : 0 V~5 V, or 0 V~10 V		
	Accuracy	2.5% of f.s.*1		
Status signal output *2	OUTON STATUS	On when output is on.		
	CV STATUS	Turns on during CV operation		
	CC STATUS	Turns on during CC operation		
	ALARM STATUS	Turns on when an alarm has been activated		
	POWER ON STATUS	Turns on when the power is turned on		
Trigger signal	Input (TRG IN)	Logic selectable : LOW (0 V~1.5 V) · HIGH (3.5 V~5 V) Input impedance : 10 kΩ (TYP)		
	Output (TRG OUT)	Logic selectable : LOW (0 V~0.6 V) · HIGH (4.2 V~5 V)		
		Pulse width : 100 μs (TYP)		

*1 f.s. is the full scale at the selected range. It is 10 V for the 10 V range and 5 V for the 5 V range.
 *2 Photocoupler open collector output; maximum voltage 30 V, maximum current (sink) 8 mA; isolated from the output and control circuits; status commons are floating (withstand voltage of less than or equal to 60 V); and status signals are not mutually isolated.

Model	400W Model	800W Model	1200W Model	2000W Model
Operation display				
OUTPUT ON/OFF	Output LED lights green when output is ON.			
Output ON/OFF delay	"DLY" Lights during setting; "DLY" blinks during operation. When output ON delay is active: output LED blinks (Orange). When output OFF delay is active: output LED blinks (Green).			
Soft start/ Soft stop	"SS" Lights during setting; blinks during operation. During soft start: output LED lights (Green). During soft stop: output LED blinks (Green).			
CV operation	CV LED lights in green.			
CC operation	CC LED lights in red.			
Alarm	ALM LED lights in red when a protection function has been activated. ALM LED blinks red when the power limit is activated. Output LED blinks orange when a protection function is activated when the output is on.			
Preset Memory	PRESET A, B, or C LED lights green when a preset memory entry is being recalled or saved.			
Key lock	LOCK LED lights green when the keys are locked.			
Remote	REMOTE LED lights green during remote control.			
LAN operation	LAN LED lights or blinks depending on the status. No fault status: lights green. Fault status: red. Standby status: lights orange. WEB identify status: blinks green.			
	Bleeder circuit	"HB" lights when the hyper bleeder is set.		
	Variable internal resistance (VIR)	"VIR" lights when it is set.		
Sequence	SEQ lights during sequence execution; SEQ lights blinks while waiting for trigger input.			

Model	400W Model	800W Model	1200W Model	2000W Model
Control functions				
External control	Output voltage control (VPGM)	0%~100% of rated output voltage Selectable control voltage range : 0V~5V, or 0V~10V		
	Accuracy	5% of rating		
	Output current control (IPGM)	0%~100% of rated output current Selectable control voltage range : 0V~5V, or 0V~10V		
	Accuracy	5% of rating		
	Output on/ off control: OUTPUT ON/OFF CONT	Logic selectable : LOW (0V~0.5V) or short-circuited: Output turns ON HIGH (4.5V~5V) or open: Output turns OFF HIGH (4.5V~5V) or open: Output turns ON LOW (0V~0.5V) or short-circuited: Output turns OFF		
	Output shutdown control: SHUT DOWN	LOW (0V~0.5V) or short-circuited: Output turns OFF		
Alarm clear control: ALM CLR	LOW (0V~0.5V) or short-circuited: Alarm is cleared			

• Applicable to the Entire Series

Model	400W Model	800W Model	1200W Model	2000W Model
Interface				
Common spec.	Software protocol	IEEE Std 488.2-1992		
	Command language	SCPI Specification 1999.0		
RS232C	Hardware	EIA232D (excluding the connector)		
		RJ-45 (male)*1		
		Baud rate: 1200, 2400, 4800, 9600, 19200, 38400, 57600, 115200 bps		
		Data length: 8 bits, Stop bits: 1 bit, Parity bit: None No flow control		
	Program message terminator	LF during reception, CR/LF during transmission		
USB	Hardware	USB2.0 , Data rate:480 Mbps (HighSpeed)		
		Socket type B		
	Program message terminator	LF or EOM during reception, LF + EOM during transmission		
	Device class	USBTMC-USB488		
LAN	Hardware	IEEE 802.3 100Base-TX/10Base-T Ethernet		
		IPv4, RJ-45 connector*2		
	Communication protocol	VXI-11 , SCPI-RAW , HiSLIP		
	Program message terminator	VXI-11, HiSLIP: LF or END during reception, LF + END during transmission SCPI-RAW: LF during reception, LF during transmission.		

*1 Optional RS-232C communication cable (RJ45 8-PIN to D-Sub 9-PIN) is available.

*2 Uses a Category 5 (Cat 5) straight-through network cable.

Model	400W Model	800W Model	1200W Model	2000W Model	
General					
Weight		Approx. 3kg	Approx. 5.5kg	Approx. 7.5kg	Approx. 13kg
Dimensions		Please Refer to the Outline Drawing			
Environment	Operating environment	Indoor use, overvoltage category II			
	Operating temperature	0 °C ~ +50 °C			
	Operating humidity	20 %rh ~ 85 %rh (no condensation)			
	Storage temperature	-25 °C ~ +60 °C			
	Storage humidity	90 %rh or less (no condensation)			
	Altitude	2000 m or less			
Cooling method	Forced air cooling using fan				
Grounding polarity	Negative grounding or positive grounding possible				
Isolation voltage	A/ B/ C type : ±500 Vmax D type : ±800 Vmax				
Withstanding Voltage	Across the primary circuit and chassis	No abnormalities when 1500 Vac is applied for 1 minute			
	Across the primary and secondary circuits	A/ B/ C type : No abnormalities when 1650 Vac is applied for 1 minute D type : No abnormalities when 1900 Vac is applied for 1 minute			
	Across the secondary circuit and chassis	A/ B/ C type : No abnormalities when 2300 Vac is applied for 1 minute D type : No abnormalities when 2640 Vac is applied for 1 minute			
Insulation Resistance	Across the primary circuit and chassis	500 Vdc · 100 MΩ or more (70 %rh or less)			
	Across the primary and secondary circuits	A/ B/ C type : 500 Vdc · 100 MΩ or more (70 %rh or less) D type : 1000 Vdc · 100 MΩ or more (70 %rh or less)			
	Across the secondary circuit and chassis	A/ B/ C type : 500 Vdc · 40 MΩ or more (70 %rh or less) D type : 1000 Vdc · 40 MΩ or more (70 %rh or less)			
Electromagnetic compatibility (EMC) *1 *2	Complies with the requirements of the following directive and standards. EMC Directive 2014/30/EU EN 61326-1 (Class A*3) EN 55011 (Class A*3 · Group 1*4) EN 61000-3-2 EN 61000-3-3 Applicable under the following conditions: The maximum length of all cabling and wiring connected to the product must be less than 3m.				
Safety*1	Complies with the requirements of the following directive and standards. Low Voltage Directive 2014/35/EU*2 EN 61010-1 (Class I*5 · Pollution Degree 2*6)				

*1 Not applicable to customized or modified products.

*2 Applicable only to models bearing the CE marking.

*3 This product is a Class A equipment, intended for use in industrial environments. In residential environments, it may cause radio interference, and users should take appropriate measures to reduce electromagnetic emissions to prevent interference with radio or television reception.

*4 This product belongs to Group 1, intended for use in material handling, inspection, or analysis applications, and is not designed to intentionally generate or use electromagnetic energy in the radio frequency range.

*5 This equipment is classified as Class I, and the protective earth terminal must be properly grounded to ensure safety.

*6 The term "pollution" refers to the presence of foreign substances (solid, liquid, or gas) that reduce insulation strength or surface resistance. Pollution Degree 2 indicates non-conductive contamination that may temporarily become conductive due to condensation.

Functions

Supports parallel and series measurement modes to achieve high current and high voltage output

• Parallel Measurement Mode

One power supply is set as the master unit while other identical models are configured as slave units.

Centralized control is performed through the master unit, enabling high-current output. (Total output current = Rated output current per unit × Number of units in parallel)

400W / 800W	Up to 3 Units in Parallel (Including Master)
1200W/ 2000W	Up to 2 Units in Parallel (Including Master)

In parallel operation mode, the voltage and current output differences between units are automatically controlled within ±5% of their rated values.

• Series Measurement Mode

Supports the series connection of up to two identical units. In series mode, the total output voltage across the load is the sum of the individual output voltages of both power supplies.

(Voltage accuracy follows the specifications of a single unit.)

Non-series-compatible models	DCS3104D, DCS3108D, DCS3112D, DCS3120D
------------------------------	--

For example, in a configuration with one master unit and two slave units, use the optional TL-DS0004 parallel communication cable.

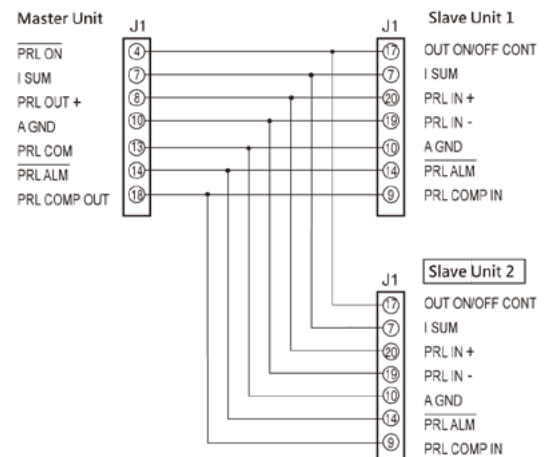

The MICROTTEST DCS-3100 Series features an exceptionally wide voltage and current setting range.

Through flexible voltage and current configuration, it can achieve approximately 3 to 4 times the output range.

By adjusting the voltage and current ratio, the output automatically adapts

Example: the DCS3112A (1200W model) can seamlessly switch between high voltage / low current mode (80V / 15A) and low voltage / high current mode (20V / 60A).

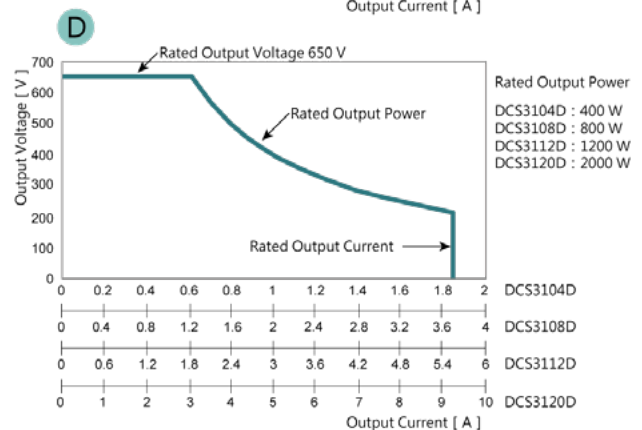
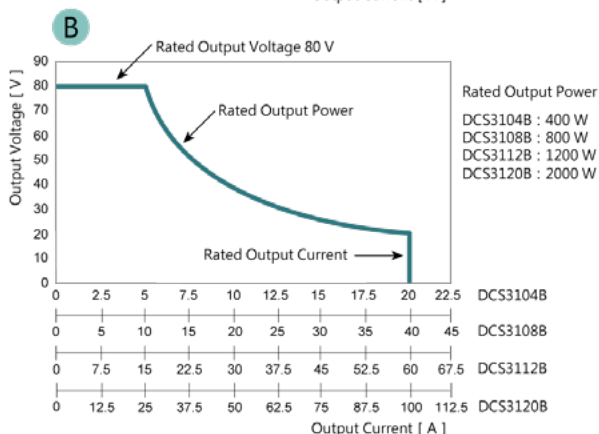
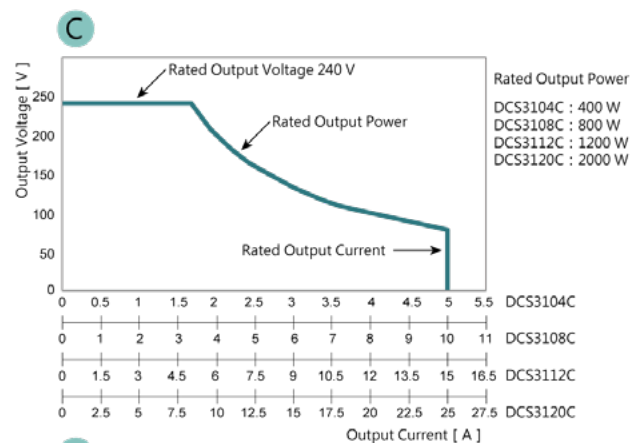
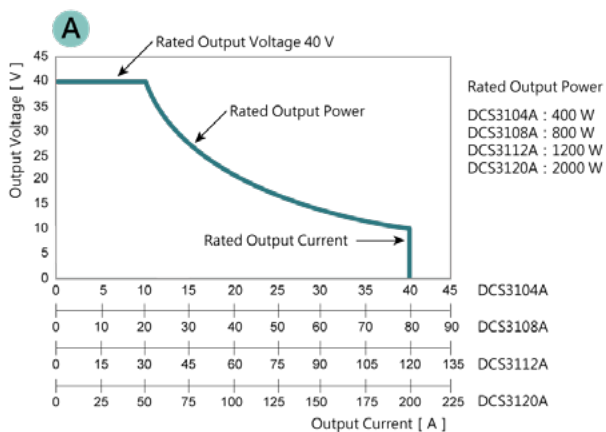

Standard LAN, USB, and RS-232C Interfaces

The MICROTTEST DCS-3100 Series comes standard with LAN, USB, and RS-232C communication interfaces.

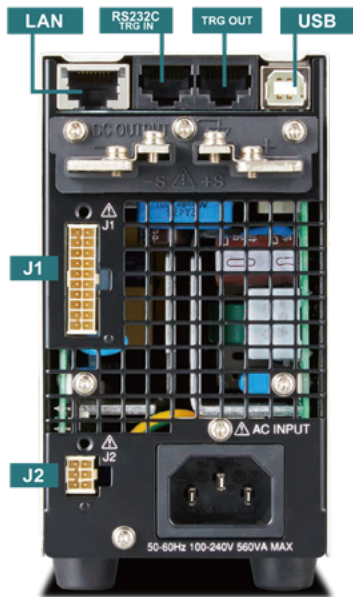

Optional Communication Accessories

Communication Interfaces	Optional Accessories
RS-232C	RS-232C Communication Cable (Optional TL-DS0005)
J1 (Rear panel)	Parallel Communication Cable for Multi-Unit Operation (Optional TL-DS0004)

Built-in 10A Front Output Terminals for Convenient Bench Operation (CAT II Rated, Max. 15A)

MICROTTEST DCS-3100 Series comes equipped with front output terminals supporting up to 10A. Optional safety plugs allow direct front-panel measurement without rack mounting or rear wiring, providing convenient operation during R&D and design validation stages.



Safety Plug (Option)



Soldered Connection Type
AX-DS0009

- Red/ Black
- 1000V/ CAT II (Max.15A)

Built-in Internal Resistance Simulation for Battery and Solar Power Analysis

MICROTTEST DCS-3100 Series supports an internal resistance simulation function. In CV mode, the output voltage automatically decreases according to the set resistance value and output current, allowing simulation of internal resistance characteristics of secondary batteries and solar cells.

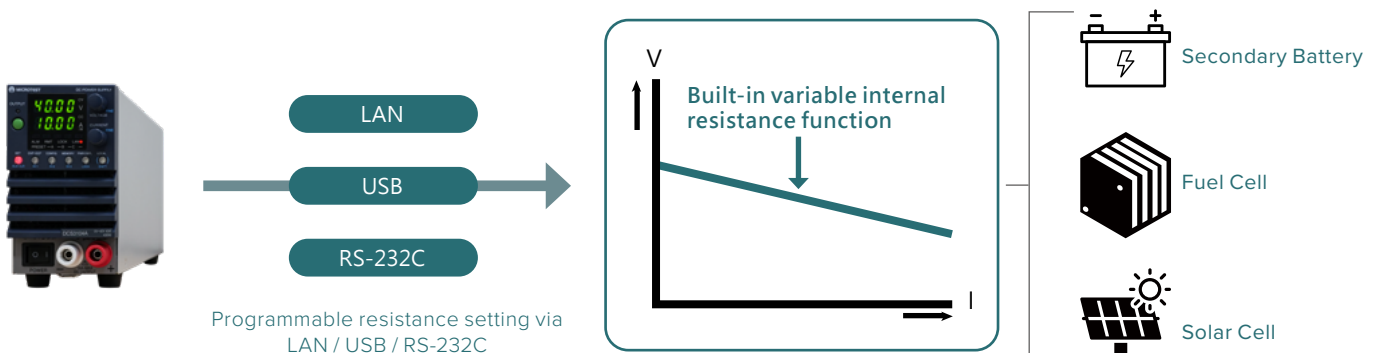

Supports VMCB Virtual Multi-Channel Architecture for Multi-Unit Control via Single PC

MICROTEST DCS-3100 Series supports the VMCB (Virtual Multi-Channel Bus) architecture, enabling control of up to 31 units from a single PC.

This allows synchronized start-up and centralized management across multiple power channels, ideal for automated test platforms, ATE systems, and multi-rail voltage sequencing for MCU, FPGA, and automotive ECU applications.

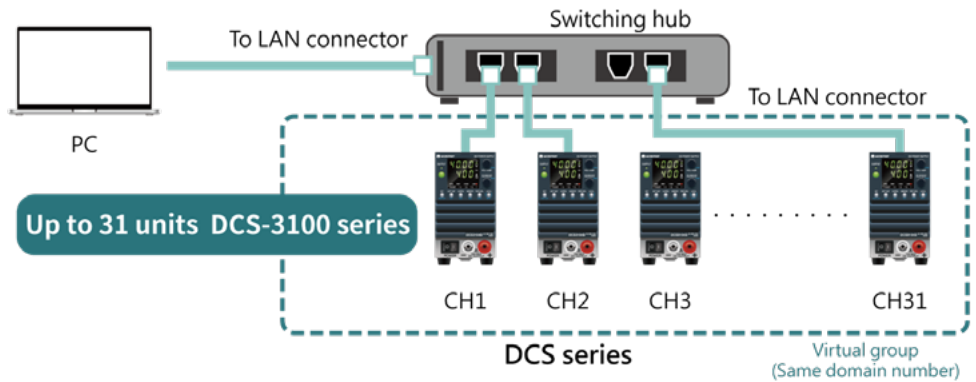

Programmable Sequencing and Synchronous Trigger for Enhanced Test Automation Efficiency

MICROTEST DCS-3100 Series features programmable sequencing and multi-unit synchronous operation. Complex test profiles can be pre-configured and stored for standalone operation without a PC. By sharing a common trigger signal, multiple DC sources of different power ratings can start simultaneously and operate in coordination, enabling synchronized multi-channel or multi-power output control for higher testing efficiency.

After setup: Even without a PC, different models of the DCS-3100 series can still be interconnected and run synchronously when multiple units are operating in parallel output.

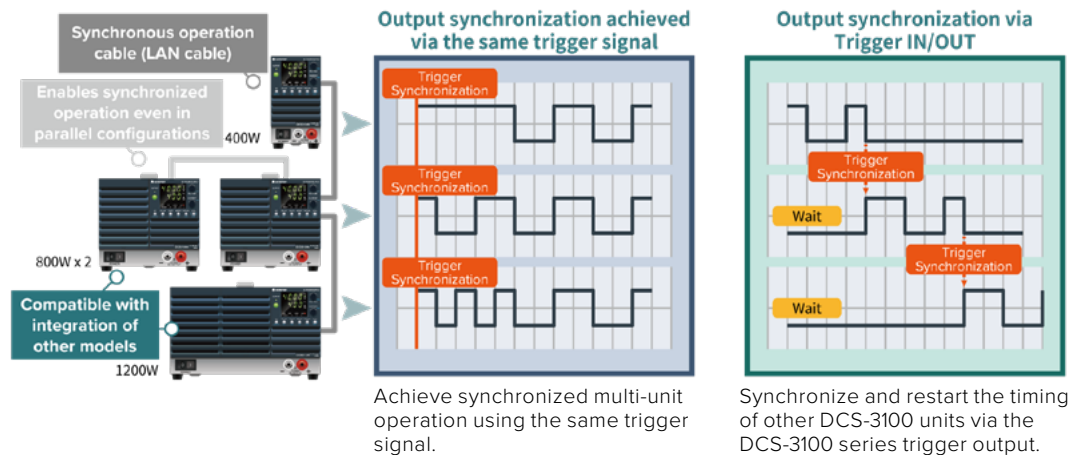

Selectable Bleeder Circuit (ON/OFF) for Safe and Efficient Discharge Control

MICROTEST DCS-3100 Series integrates a switchable Bleeder Circuit (ON/OFF) that provides active discharge capability. When the output is turned off, it quickly releases residual voltage from internal capacitors or connected loads, accelerating voltage decay and improving testing efficiency. For energy-storing DUTs such as batteries, the bleeder circuit can be disabled to prevent reverse current flow, eliminating the need for external protection diodes.



Bleeder Mode Settings :

OFF

When the output is turned off or set to 0 V with the output terminal open, a residual voltage of up to several hundred millivolts may appear at the terminal. This is a normal condition.

ON | Normal bleeder

When the output is turned off, the active discharge mechanism is automatically activated to release residual voltage at a controlled rate, ensuring operational safety and reducing risks in subsequent tests.

OUTPUT OFF & No Load | Hyper bleeder

When the output is turned off (OUTPUT OFF) and no load is connected, a high-speed fan accelerates the discharge process, reducing the discharge time by up to 70% compared to normal discharge mode. This enhances testing efficiency, especially for high-frequency ON/OFF testing of power devices.

Supports Three Start/Control Modes for Stable Output Without Surges

• Output Mode Priority (C.V/C.C)

Allows preselection of constant voltage (C.V) or constant current (C.C) at startup to minimize initial surge risk.

• Output Delay Setting

Enables setting a delay after pressing the OUTPUT key, allowing precise control according to load requirements.

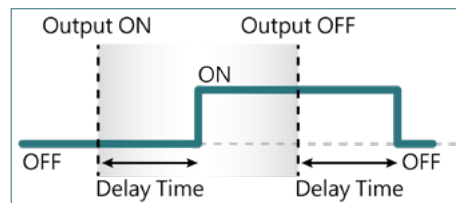

• Soft Start/Stop

Adjustable rise and fall times of output current to prevent inadvertent activation of protection mechanisms due to rapid current changes.

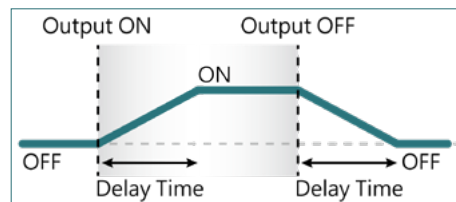

Supports External Signal Control

The MICROTTEST DCS-3100 Series supports external voltage and resistance control through analog interfaces. Via the rear panel J1/J2 interfaces, external signals can control and monitor the test power supply.

External Voltage Control	External Resistance Control	External Contact			Operation Mode Monitoring
		ON/OFF	Stop	Alarm Reset	
<p>2-core shielded wire or twisted pair wires</p>	<p>2-core shielded wire or twisted pair wires</p>	<p>2-core shielded wire or twisted pair wires</p>	<p>2-core shielded wire or twisted pair wires</p>	<p>2-core shielded wire or twisted pair wires</p>	External monitoring of output voltage and current.
Apply external voltage to control output voltage and current.	Adjust external resistance to control output voltage and current.	Control DCS series output ON/OFF via external contacts.	Shut down output via external contact.	Cancel alarms via external contact.	

Ordering Information

DC Power Supply DCS-3100 Series	Output Power	Voltage output	Current output
DCS3104A	400W	0V~40V	0A~40A
DCS3104B		0V~80V	0A~20A
DCS3104C		0V~240V	0A~5A
DCS3104D		0V~650V	0A~1.85A
DCS3108A	800W	0V~40V	0A~80A
DCS3108B		0V~80V	0A~40A
DCS3108C		0V~240V	0A~10A
DCS3108D		0V~650V	0A~3.70A
DCS3112A	1200W	0V~40V	0A~120A
DCS3112B		0V~80V	0A~60A
DCS3112C		0V~240V	0A~15A
DCS3112D		0V~650V	0A~5.55A
DCS3120A	2000W	0V~40V	0A~200A
DCS3120B		0V~80V	0A~100A
DCS3120C		0V~240V	0A~25.0A
DCS3120D		0V~650V	0A~9.25A

Standard	Optional
<ul style="list-style-type: none"> TL-DS0001 AC Power Cord 400W/800W Model AX-DS0001 Grounding Shorting Bar (connects to chassis base) AX-DS0002 M4 Screws for output terminals AX-DS0003 M8 Screws for output terminals 400W/800W/1200W-40V/80V Model AX-DS0004 M10 Screws for output terminals 2000W-40V/80V Model AX-DS0005 Output Terminal Protective Cover 400W/800W/1200W Model AX-DS0006 Output Terminal Protective Cover 2000W Model AX-DS0007 Input Terminal Protective Cover 1200W Model AX-DS0008 EMI Suppression Core Kit 1200W Model 	<ul style="list-style-type: none"> TL-DS0002 AC Power Cord 1200W Model TL-DS0003 AC Power Cord 2000W Model TL-DS0004 Parallel Communication Cable TL-DS0005 RS-232C Cable (RJ45 8PIN TO D-Sub 9 PIN) AX-DS0009 Safety Plug (Soldered Connection Type)

External Dimensions

• Dimensions (mm)

• 400W Model

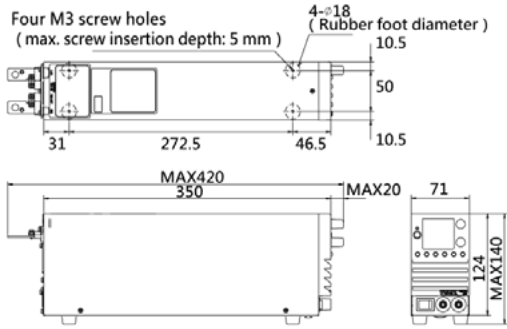

• 800W Model

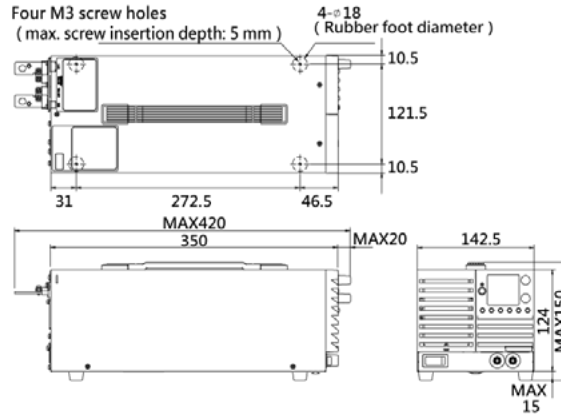

• 1200W Model

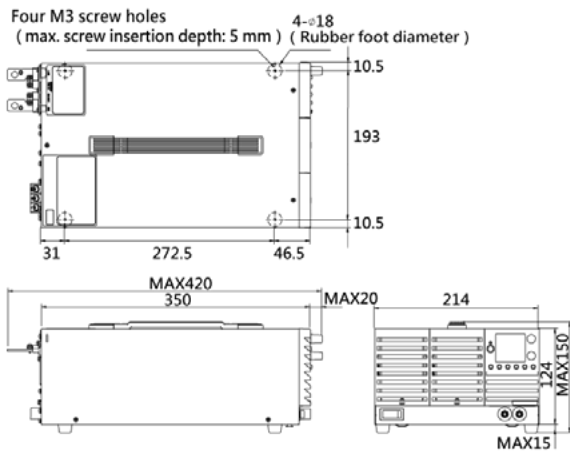

• 2000W Model

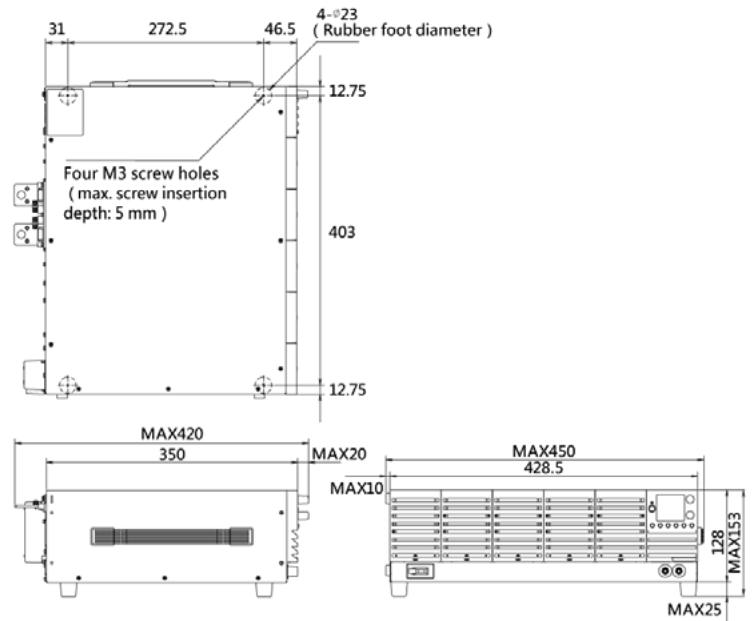

Rear panel



• 400W Model



• 800W Model



• 1200W Model



• 2000W Model