

Motor Stator & Motor Rotor Safety and Low-Voltage Testing Solution

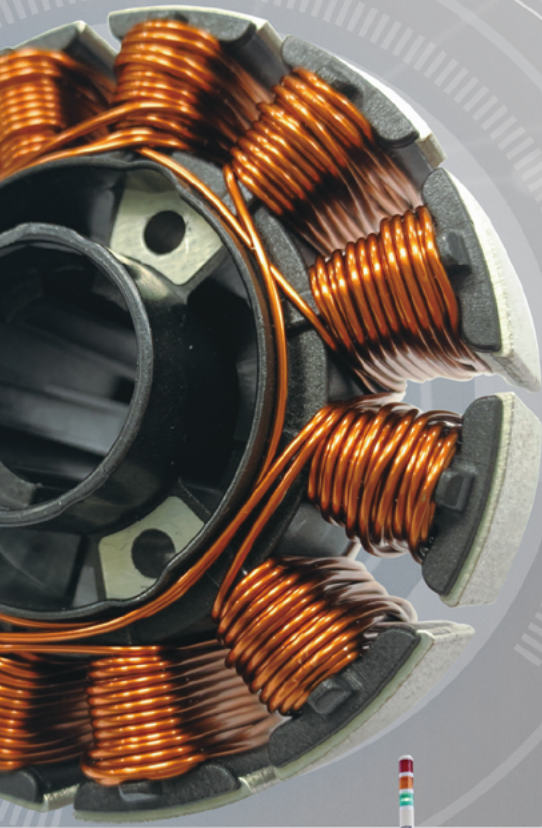

AC/DC Hipot & IR
Test



Impulse Winding
Test



DCR Test



Welding
Resistance



3-Phase Current
Balance Test



3-Phase Inductance
Balance Test



Home
Appliances



Consumer
Electronics



UAVs



Electric
Vehicles



Industrial
Automation



Agricultural
Machinery



Motion
Furniture



Medical
Devices



E-Bikes



Automotive
Systems

The MICROTEST Motor Stator/Rotor Testing System consolidates safety and low-voltage electrical characterization into a single high-efficiency workstation. This system performs comprehensive testing on AC/DC Hipot, insulation resistance, impulse winding, DCR, inductance, 3-phase current balance, phase rotation and welding resistance.

It supports PC Link Software for remote programming and data logging, and offers customized test fixtures and PLC control integration tailored to specific production requirements.

Motor Stator Testing System

6910/6913/6917+7605

8/13/17 Channel Hipot/ IR/ DCR/ Impulse Winding/ Inductance/ Polarity Test

Motor Tester



• Rack



• Benchtop

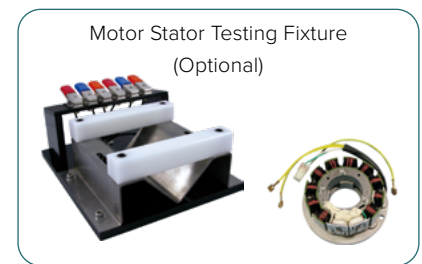

The MICROTEST Motor Stator/Rotor Testing System provides a one stop, integrated solution for Hipot test and low voltage electrical characterization. Supporting multi channel configurations and customized test fixtures, the system allows for seamless testing of complex stator and rotor designs. It features PC Link Software for remote programming and data logging, with full support for PLC control integration.

The MT-6917/ MT-6913/ MT-6910 offers 17, 13, and 8-channel testing capabilities, respectively. These systems consolidate Hipot, insulation resistance, and impulse winding testing into a single platform. For resistance measurements, 4-wire sensing technology is utilized with an integrated Temperature Compensation function to ensure precision. The system further verifies stator polarity through Phase Rotation Testing and can be integrated with the LCR 6365 for advanced inductance measurement, providing a complete, one stop inspection for motor stator coils.

Application

Motor | Motor Stator



Standard Interfaces

RS-232

Feature

- One stop motor coil measurement solution, measuring items included inductance, AC/DC hipot, impulse winding, DCR (temperature compensation), polarity
- 4-wire DCR measurement
- Storage file up to 100 sets
- It can test multiple sets of DUTs simultaneously (depending on the number of winding set of the product)
- Arcing detection function
- Waveform Comparison: Detects Layer to Layer Short Circuits
- The Impulse/Surge with waveform comparison is a non-destructive analysis
- PC connection data analysis software is available
- Support Three-phase Current Balance Test (Option)

Specification

Model	MT-6910	MT-6913	MT-6917	MT-6913L	
DCR Range (with temperature compensation)	0.1mΩ~100kΩ			0.1mΩ~150Ω	
DCR Accuracy	Low Resistance : 0.1mΩ~1Ω ±(0.2%±1mΩ), High Resistance : 1Ω~100kΩ±0.1%			0.1mΩ~200mΩ ±(0.1%±0.5mΩ) 200mΩ~1Ω ±(0.1%±2mΩ) 1Ω~150Ω±0.5%	
Three phase Resistance Balance Test	Comparison Mode	<ol style="list-style-type: none"> 1. Absolute difference between two sets of coil resistance values. 2. The ratio of the absolute value of the difference between the two groups of coil resistance to the standard value. 3. The ratio of the absolute value of the difference between the resistance of two sets of coils to the average value of the measured resistance of three sets of coils. 			
Three phase Current Balance Test	Voltage (Max.)	220V			
	Current (Max.)	30A			
Measuring Mode	4-Wire				
Channel	8	13	17	13	
Hipot Test	AC Output Voltage	100V~5000V	100V~3000V	100V-3000V	100V~3000V
	DC Output Voltage	100V~6000V	100V~3000V	100V-3000V	100V~3000V
	IR Output Voltage	100V~1000Vdc			
	AC Leakage Current	0.001mA~10mA			
	DC Leakage Current	0.001mA~5mA			
	IR Lower Threshold	1~9999MΩ			
	Arcing Detection	Detect gears from 0-9			
	Measuring Time	0.1-99.9s Continuously adjustable			
	Measuring Time Accuracy	±(3% of setting+5V)			
Impulse Winding Test	Impulse Voltage (programmable)	200V~5000V	200V~3000V		
	Impulse Voltage Accuracy	±2%			
	Waveform Comparison	Total Area Comparison, Differential Area Comparison, Wave Comparison, Flutter and Corona			
6365 LCR Meter (Option)					
Frequency Range	10Hz~200kHz				
Inductance Measurement Ranges	0.1nH~100kH				
AC Drive Level	10mV~2Vrms (1mV resolution)				
Basic Accuracy	±0.1%				
Frequency Output Accuracy	±0.01%				
Three-phase Inductance Balance Test	Comparison Mode	<ol style="list-style-type: none"> 1. Absolute value of the difference between the two sets of coil inductance. 2. The ratio of the absolute value of the difference between the two sets of coil inductance to the standard value. 3. The ratio of the absolute value of the difference between the inductance of the two sets of coils and the average value of the measured resistance of the three sets of coils. 			

General

Test fixture	According to the test requirements
Indicator	Pass/Fail Screen Diaplay/Sound
Power Supply	Voltage : 90~132Vac or 198~264Vac
Power Consumption	350VA (691X+7605)
Interface	RS-232
PC Link Software	●
Built-in Storage	Storage of 100 rewritable data sets
Operation	Manual, RS-232
Environment	Temperature : 10°C~40°C, Humidity : 20~90%RH
Display	7.0" TFT, 800×480 Color LCD (6365), 5.7", 320*240 dot-matrix display (6910/6913/6917), 4.3" TFT, Color LCD (7605)
Dimension (W*H*D)	435x145x522mm (6365), 435x190x522mm (6910/6913/6917), 435x145x522mm (7605)
Weight	9kg (6365), 15Kg (6910/6913/6917), 14Kg (7605)

Motor Rotor Testing System

MT-6920

24/48 Channel

Hipot/ IR/ DCR/ Impulse Winding/ Welding Resistance

Motor Tester

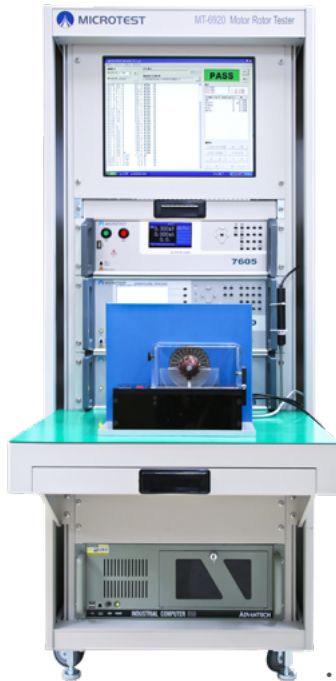

• Rack



• Benchtop

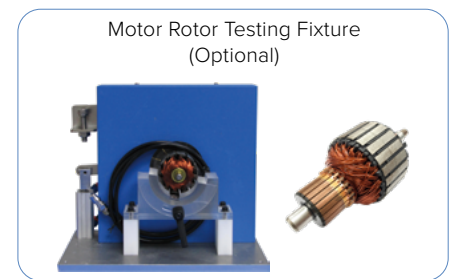

MICROTEST MT-6920 Motor Rotor Testing System combines the Interlayer Short Circuit Tester (6920), the High Voltage Withstand Tester (7605), and the Multi Channel Control Box (6908), with the 6920 serving as the main controller. It allows for the configuration of all measurement parameters and provides 24/48 test channels. The external PC software enables direct real time access to test results from the 6920, as well as report generation and direct uploading of test results to a database. MT-6920 Motor Rotor Testing System offers 24/48 channel testing capability for measuring the welding resistance of motor rotors. It integrates safety compliance, high voltage insulation, and coil interlayer short-circuit testing into one system. It supports remote programming and data storage via PC connectivity software and can be equipped with PLC control. Customized test fixtures can be provided for rotor testing according to customer specifications.

Application

Motor | Motor Rotor



Standard Interfaces

RS-232

Feature

- One stop motor coil measurement solution, measuring items included inductance, AC/DC hipot, impulse winding, DCR (temperature compensation) and welding resistance
- 4-wire DCR measurement
- The 6920 impulse winding tester is the host instrument, all settings can be completed on the host
- Storage file up to 100 sets
- Arcing detection function
- Waveform Comparison: Detects Layer to Layer Short Circuits
- The Impulse/Surge with waveform comparison is a non-destructive analysis
- PC connection data analysis software is available

Specification

Model	MT-6920 (7605+6920+6908)	
DCR Range (With Temperature Compensation)	0.1mΩ~100kΩ	
Welding Resistance	0.01mΩ~1Ω	
DCR Accuracy	Low Resistance : 0.1mΩ~1Ω ±(0.2%±1mΩ) High Resistance : 1Ω~100KΩ ±0.1%	
Measuring Mode	4-Wire	
Channel	24/48	
Hipot Test	AC Output Voltage	100V~3000V
	DC Output Voltage	100V~3000V
	IR Output Voltage	100V~1000Vdc
	AC Leakage Current	0.001mA~10mA
	DC Leakage Current	0.001mA~5mA
	IR Lower Threshold	1~9999MΩ
	Arcing Detection	Detect gears from 0-9
	Measuring Time	0.1-99.9s Continuously adjustable
	Measuring Time Accuracy	±(3% of setting+5V)
Impulse Winding Test	Impulse Voltage (programmable)	200V~3000V
	Impulse Voltage Accuracy	±2%
	Test Items	Total Area Comparison, Differential Area Comparison, Wave Comparison, Flutter and Corona

General

Test Point	Depends on the Number of Slots that Matches with the Customer Products (Fixtures)
Indicator	Pass/Fail Screen Display/Sound
Power Supply	Voltage 90-132Vac or 198-264Vac
Power Consumption	450VA (7605+6920+6908)
Interface	RS-232
PC Link Software	●
Built-in Storage	Storage of 100 rewritable data sets
Operation	Manual, RS-232
Environment	Temperature: 10°C~40°C, Humidity: 20~90%RH
Display	4.3" TFT, Color LCD (480*272) (7605) 5.7" TFT (320*240) (6920)
Dimension (W*H*D)	435x145x522mm (6908) 435x190x522mm (6920) 435x145x522mm (7605)
Weight	14Kg (7605) 、 15Kg (6920) 、 7Kg (6908)

Motor Testing - System Configuration & Planning

MICROTEST Stator/Rotor Testing Solutions: Configure Your System Based on the Table Below

1. Evaluate System Architecture Based on Production Needs

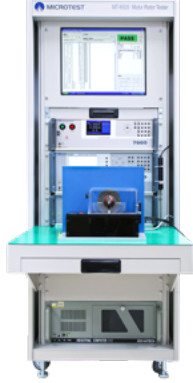
Benchtop	Rack
	
<p>MICROTEST provides standalone desktop instruments, allowing users to perform settings and testing directly on the unit. Final measurement data can be efficiently collected via the RS-232 interface.</p>	<p>A comprehensive system integrated into a professional rack, featuring an Industrial PC (IPC), monitor, Pass/Fail indicators, and a dedicated fixture workstation table tailored to production line requirements.</p>

2. Evaluate whether to include PC Link Software

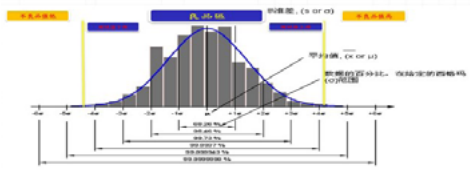
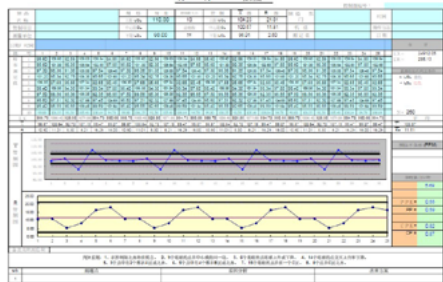
Evaluate whether to include PC connectivity software		
Function	Operate directly on the instrument	PC Link
Production Traceability Management - Implementing Bar Code/ Label Printer/ Laser Engraver	/	●
Store test file sets	100 sets (existing instruments)	Unlimited (according to PC memory)
Sharing test files between devices	Unable to share, recreate the file	Share through PC software
Accessing test data	/	Transfer test data to the PC via the RS-232 interface
Uploading test data to a cloud database	/	●
User Permission Management or User Access Control	/	Supports permission management, configuration through Engineering Mode
CPK Report	/	
Customized CPK Report According to Customer Requirements	/	

3. Define Testing Requirements



MT-6910/ MT-6913/ MT-6917 Stator Testing Suite

AC/DC Hipot & Insulation Resistance <u>Winding to Stator Core</u>	Impulse Winding Test <u>Inter-turn Insulation & Life Expectancy</u>	DCR	Inductance	Three phase Current Balance Test	Phase Rotation & Polarity Test
<ul style="list-style-type: none"> • Basic Insulation Level • Reinforced Insulation Level • Winding Insulation Integrity • Total Creepage Distance • Clearance Distance 	<ul style="list-style-type: none"> • Inherent Coil Defects • Inter turn Short Circuits • Cross over Short Circuits • Lead wire Short Circuits • Enameled Wire Insulation Failure 	Utilizes 4-wire sensing for precise resistance measurement. For instance, in 3-phase motors, DCR values exceeding standard specifications are a primary cause of operational imbalance.	Verifies inductance to detect anomalies in core material, winding turn counts, or assembly craftsmanship.	Manufacturers typically perform 3-phase current balance testing at the stator stage to eliminate issues such as inter-turn shorts, partial grounding, or internal short circuits. This ensures proper conductivity and consistent turn counts, achieving a uniform magnetic field while significantly reducing the defect rate of finished products.	Ensures correct winding phase sequence and magnetic polarity to prevent reverse motor rotation. This eliminates risks such as equipment damage, reduced efficiency, or potential safety hazards during operation.

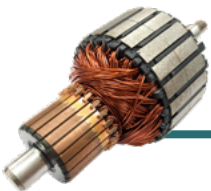

MT-6920 Rotor Testing Suite

AC/DC Hipot & Insulation Resistance <u>Winding to Stator Core</u>	Impulse Winding Test <u>Inter-turn Insulation & Life Expectancy</u>	DCR	Welding Resistance
<ul style="list-style-type: none"> • Basic Insulation Level • Reinforced Insulation Level • Winding Insulation Integrity • Total Creepage Distance • Clearance Distance 	<ul style="list-style-type: none"> • Inherent Coil Defects • Inter-turn Short Circuits • Cross over Short Circuits • Lead wire Short Circuits • Enameled Wire Insulation Failure 	Utilizes 4-wire sensing for precise resistance measurement. For instance, in 3-phase motors, DCR values exceeding standard specifications are a primary cause of operational imbalance.	Prevents excessive welding resistance in the rotor, which can lead to localized overheating and significantly shorten the motor's operational lifespan.

Functions

Motor Tester

Integrated One Stop Safety & Low-Voltage Electrical Testing

Insulation Test Setting		Prog
File: 123	1/1	
Channel+	12	
Channel	34	
Voltage	1.0 kV	
Dwell	1.0 Sec	
Ramp	0.1 Sec	
Maximum	9999 MΩ	Copy
Minimum	100 MΩ	Del.
Arc Sen.	0	
DUT No.	1	EXIT

I. Test Setting		Rate: FAST	
File: 123	1/2		Meas
UI+	1	3	
UI-	2	4	
Std	9.149	8.982	
Max	10.064	9.000	
Min	8.234	8.084	
Unit	mH	mH	Copy
Freq	1.0kHz	1.0kHz	Del.
Unit	1.00uH	1.00uH	
UPI's	0.00uH	0.00uH	
DUT#	1	1	EXIT

123							
1	CH(1,3)	IR	10.00	GΩ	OK	PASS	
1	CH(1,3)	HIPOT	0.034	mA	OK		
1	CH(1,2)	Area	-0.1	%	OK		
1	CH(1,2)	Diff	0.1	%	OK		
1	CH(1,2)	Flut	332		OK		
1	CH(1,2)	Comp			OK		
1	CH(1,2)	Coro	0		OK		
1	CH(3,4)	Area	-0.2	%	OK		
1	CH(3,4)	Diff	0.1	%	OK		
1	CH(3,4)	Flut	374		OK		
1	CH(3,4)	Comp			OK		
1	CH(3,4)	Coro	0		OK		
1	CH(1,2)	Rdc	1.405	Ω	OK		
1	CH(3,4)	Rdc	1.370	Ω	OK		
1	CH(1,2)	L	9.204	mH	OK		
1	CH(3,4)	L	8.986	mH	OK		

Test completed Wave

AC/DC Hipot & Insulation Resistance

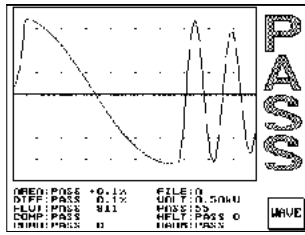

TEST PARAMETER		ON
MATH WAVE		
UNIFORM AREA SIZE	<input checked="" type="checkbox"/>	DEF
DIFFERENTIAL AREA SIZE	<input checked="" type="checkbox"/>	
FLUTTER VALUE	<input checked="" type="checkbox"/>	
UNIFORM COMPARISON	<input checked="" type="checkbox"/>	SET-UP
CORONA VALUE	<input checked="" type="checkbox"/>	
HARMONIC		
NOISE HEIGHT	<input checked="" type="checkbox"/>	
FLUTTER VALUE	<input checked="" type="checkbox"/>	EXIT

Impulse Winding Test

Hipot. Test Setting		Prog
File: 123	1/1	
Channel+	12	
Channel	34	
UnitFreq	1.0kV 50Hz	
Dwell	1.0 Sec	
Ramp	0.1 Sec	
Maximum	1.000 mA	Copy
Minimum	0.000 mA	Del.
Arc Sen.	0	
UPI'set	0.000 mA	
DUT No.	1	EXIT

Inductance Test

- AC/DC Hipot & Insulation Resistance
- Impulse Winding Test
- DCR Test
- Inductance Test

Non Destructive High Voltage Impulse Testing for Layer Short Detection

Utilizes high speed impulse voltage applied across the motor windings. This non-destructive method leverages L-C resonance to generate a damped oscillatory waveform. By comparing the instantaneous waveforms of the DUT (Device Under Test) against a known standard, the system can preemptively identify layer-to-layer shorts, internal winding defects, or core insulation flaws, ensuring long-term product reliability.

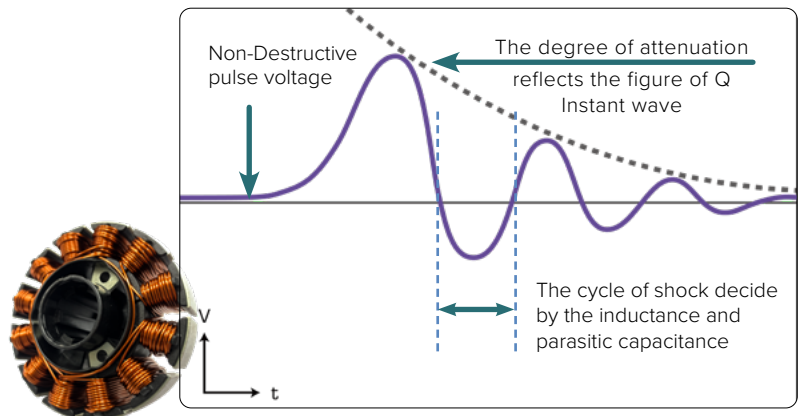

High Precision 4-Wire DCR Measurement

Employs 4-wire sensing technology to eliminate lead resistance. In 3-phase induction motors, DCR imbalance is a primary cause of operational instability and uneven torque distribution.

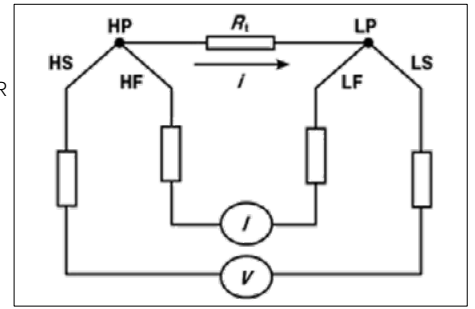

3-Phase Current Balance Test (Optional)

3-phase current imbalance generates negative sequence currents and negative sequence magnetic fields, leading to operational instability, reduced efficiency, vibration, and noise. Prolonged exposure to these conditions increases the risk of overheating and significantly shortens the motor's lifespan. To minimize high defect rates in finished motors, many manufacturers integrate 3-phase current testing at the stator (semi-finished) stage. This effectively detects inter turn shorts, partial grounding, or internal short circuits that cause excessive current in a single phase.

Testing Objectives:

1. Ensuring Electrical Connectivity via Average Current Testing
2. Achieving Magnetic Field Symmetry through Winding Turn Consistency

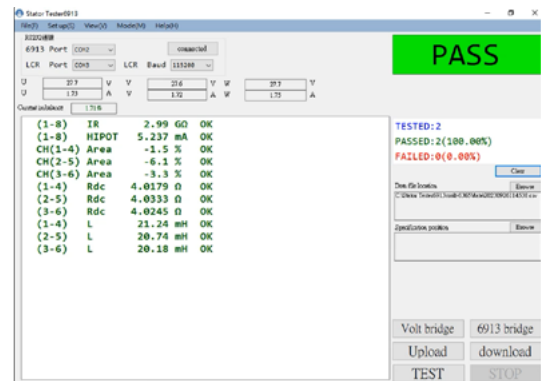
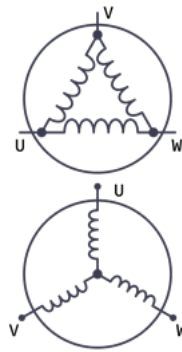

Ordering Information

Motor Testing System	Standard	Optional
<ul style="list-style-type: none"> Motor Stator Testing System MT-6910 (8 channel) Motor Stator Testing System MT-6913 (13channel) Motor Stator Testing System MT-6913L (13channel/ Low Resistance) Motor Stator Testing System MT-6917 (17channel) Motor Rotor Testing System MT-6920 (24channel) Motor Rotor Testing System MT-6920 (48channel) 	<p>MT-6910/ MT-6913/ MT-6913L/ MT-6917</p> <ul style="list-style-type: none"> AX-MT0001 Temperature Test Prob TL-MT0001 Single Ended RCA-HV Test Cable (200cm) TL-000004 RS-232 Cable (180cm) TL-MT0003 HV Plug-HV Test Cable-Red (40cm) 6905 TO 691X TL-MT0004 HV Plug-HV Test Cable-Black (40cm) 6905 TO 691X Power Cord <p>MT-6920</p> <ul style="list-style-type: none"> AX-MT0001 Temperature Test Prob TL-MT0009 RCA-HV Test Cable-Black (30cm) TL-MT0002 Banana Plug-HV Test Cable-Black (30cm) TL-MT0005 Banana Plug-HV Test Cable-Black (15cm) 7605 TO 6920 TL-MT0007 Adapter Flat Cable (30cm) 6920 TO 6908-24CH TL-MT0008 Adapter Flat Cable (30cm) 6920 TO 6908-48CH Power Cord 	<ul style="list-style-type: none"> TL-000004 RS-232 Cable (180cm) TL-000005 D-Sub Cable- 25F TO 25F (180cm) F760001 D-Sub Foot Switch (15 PIN) AX-MT0002 D-Sub Foot Switch (25 PIN) PC Link Software

Fixture & Accessories

AX-MT0001

Temperature Test Prob



TL-MT0001

Single Ended RCA-HV Test Cable



TL-000004

RS-232 Cable



Applicable Models	MT-6910/ 6913/ 6917/ 6920	MT-6910/ 6913/ 6917	MT-6910/ 6913/ 6917/ 6920
Accessory Description	Temperature Test Prob	200cm	180cm

TL-MT0002

Banana Plug-HV Test Cable-Black



TL-MT0005

Banana Plug-HV Test Cable-Black



TL-MT0009

RCA-HV Test Cable-Black



Applicable Models	MT-6920	MT-6920	MT-6920
Accessory Description	30cm	15cm 7605 TO 6920	30cm

F760001

Foot Switch



AX-MT0002

D-Sub Foot Switch



TL-000005

D-Sub Cable



Applicable Models	MT-6910/ 6913/ 6917/ 6920	MT-6910/ 6913/ 6917/ 6920	MT-6910/ 6913/ 6917/ 6920
Accessory Description	15 PIN	25 PIN	180cm 25F TO 25F

TL-MT0003

HV Plug-HV Test Cable-Red

TL-MT0004

HV Plug-HV Test Cable-Black

TL-MT0007

Adapter Flat Cable

Applicable Models	MT-6910/ 6913/ 6917	MT-6910/ 6913/ 6917	MT-6920
Accessory Description	40cm 6905 TO 691X	40cm 6905 TO 691X	30cm 6920 TO 6908-24CH

TL-MT0008

Adapter Flat Cable

Applicable Models	MT-6920
Accessory Description	30cm 6920 TO 6908-48CH