

Complying with EU 2023/826 Energy Efficiency Regulations

Detailed solutions for high CF, low PF, and pulse distortion challenges

Start with the MICROTEST 7140 Power Analyzer

Accurately meets IEC 62301 Ed.2 standby power test requirements



Standby Power Consumption

- ◆ Unexpected Challenges in Standby Power Testing
- ◆ Extremely Low Current and Power, High Crest Factor, and Low Power Factor

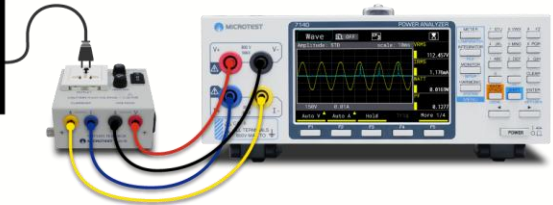

With the global push for energy saving and carbon reduction, standby power consumption has become a key indicator of both regulatory compliance and product competitiveness. The new EU regulation (EU) 2023/826, effective in May 2025, imposes stricter limits on power consumption in off and standby modes. This requires the adoption of high-precision measurement and verification mechanisms at the product design stage.

However, testing standby power presents greater challenges than expected—extremely low current and power, high crest factor, and low power factor. This article provides a concise overview of the EU 2023/826 requirements, starting with IEC 62301 Ed.2 compliance. It introduces a comprehensive standby power measurement solution to help engineers accurately capture every milliwatt of power consumption.

- P1** ■ EU 2023/826 Regulatory Requirements
- P2** ■ Overcoming the Three Major Challenges in Standby Power Testing
- P3** ■ Starting from IEC 62301 Ed.2 | The International Standard for Standby Power Measurement
- P12** ■ Detailed solutions for high CF, low PF, and waveform distortion issues
- P13** ■ MICROTEST 7140 Power Analyzer | Milliwatt-Precision Measurement
- P15** ■ Comparison Chart | 100kHz Power Analyzer

According to the Lawrence Berkeley National Laboratory (LBNL), standby power is defined as "the electricity continuously consumed by electrical equipment in its lowest power mode." For example, televisions and microwaves maintain digital clock displays or keep remote control functions active while in standby mode. Laptops, tablets, and smartphones continue to draw power even when not in use, as their power adapters remain active. Surprisingly, a microwave's standby energy consumption over an entire year can exceed the energy used for actual cooking, because the device spends far more time in standby than in active heating. Although standby power may seem small, its cumulative energy use and carbon impact become significant when multiplied across many devices over long periods.

The EU 2023/826 energy efficiency regulation, fully enforced from May 9, 2025, covers a wider range of products including household and office equipment, electric furniture, building equipment (e.g., motorized doors and blinds), low-voltage devices under 6 V, portable battery-powered products in a fully charged standby state, as well as printers and simple set-top boxes. The regulation sets stricter limits: from 2025, general products must consume no more than 0.5 W in standby or off mode; devices with a display or indicator in standby must not exceed 0.8 W. From 2027, the off-mode limit drops to 0.3 W, standby remains 0.5 W, and network-connected devices have a standby power limit of 2–7 W depending on type.



EU 2023/826 Requirements – Quick Reference Table

Energy Efficiency Requirements		(EU) 2023/826		(EU) No 801/2013
		2025/5/9	2027/5/9	2025/5/9 (Before)
Off-Mode Power		≤0.50W	≤0.3W	≤0.50W
Standby Power	No Display	≤0.50W		≤0.50W
	Standby with Display	≤1.00W (Household tumble driers) ≤0.80W (Others)		≤1.00W
Networked Standby Power	HiNA Networked Standby (Note A)	8.00W	7.00W	8.00W
	Non-HiNA Networked Standby	2.00W		2.00W

Regulated Products

- Motorized Furniture
- Motorized Building Equipment (e.g., electric doors, windows, and blinds)
- Low-Voltage Devices under 6 V
- Portable Battery Products in Fully Charged Standby
- Printers (excluding 3D Printers)
- Simple Set-Top Boxes

Note A – Devices with High Network Availability (HiNA)

These are devices that must maintain network connectivity while in standby mode and provide fast response capabilities. Such devices continue background network communication during standby, typically consuming more power than standard standby devices. Examples include routers, switches, modems, wireless access points, IP phones, video phones, and hybrid set-top boxes that can receive signals or wake-up commands in real time.

Quick Analysis of the Three Major Challenges in Measuring Standby Power

Low Power | High Crest Factor | Transient Fluctuations

As energy efficiency and carbon reduction become core design values, standby power determines whether a product meets regulatory requirements such as Energy Star or EUErP. To effectively reduce standby power during the development of electrical products, the first step is to understand how to accurately measure it.

Before starting measurements, it is important to recognize that measuring standby power is not as simple as reading a “wattage” value. The power characteristics in standby mode are complex, and measurement must overcome the following three major challenges:

■ Extremely Low Power and Small Currents Leading to Distorted Waveforms

For example, consider measuring the standby power of a 10mW product in Europe, with an input voltage of 230 V and a power factor of 1. Using the formula

$$\text{Power (W)} = \text{Voltage (V)} \times \text{Current (A)} \times \text{Power Factor}$$

For 10mW (0.01 W) standby power, the current is

$$\text{Current} = 0.01 \div 230 = 43.5\mu\text{A}$$

Such a tiny standby current of 43.5 μA is usually not a smooth sine wave, but rather short, irregular pulses with very high peaks.

Under light-load operation, most electronic devices in standby only draw brief current pulses to charge internal capacitors when the input voltage reaches its peak. If the power analyzer’s sampling rate is insufficient, these high-crest-factor pulses may be missed, leading to underestimation of the actual current and power, and resulting in distorted measurement data.

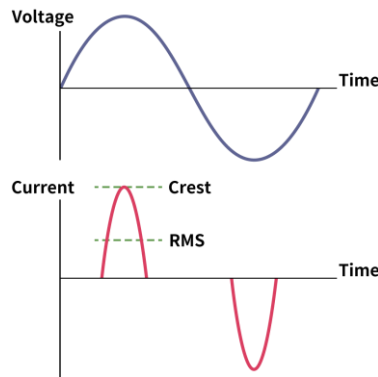

■ Low Power Factor

When a device is in standby mode, most of the current drawn comes from capacitive components (e.g., EMC filters in the power supply). This current mainly circulates to charge and discharge electric fields rather than being actual power consumption. As a result, a significant phase difference between voltage and current occurs, leading to a low power factor.

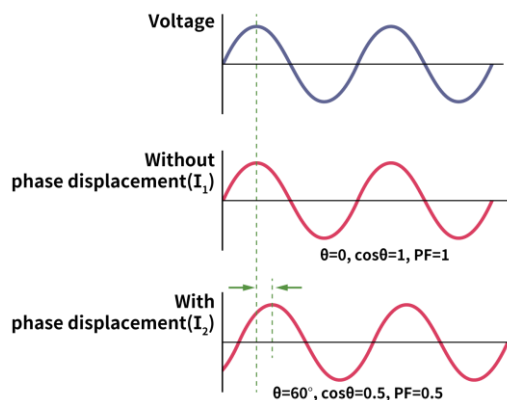

How to Measure Standby Power?

Achieve Low-Power Designs Starting with IEC 62301 Ed.2 Compliance

Under global energy-saving and carbon reduction policies, standby power consumption has become a critical indicator in both product design and regulatory review. The International Electrotechnical Commission (IEC) has established IEC 62301, the international standard for measuring standby power in household appliances. Its second edition, IEC 62301 Ed.2, provides comprehensive revisions addressing practical measurement scenarios such as variable power draw, periodic currents, and networked standby functions. This standard serves as the technical basis for power consumption testing of digital appliances, communication devices, and other electronic products.

For product development engineers, IEC 62301 Ed.2 is the key international reference for standby power testing. Compliance with this standard is also required to meet EU regulations (Commission Regulation (EC) No 1275/2008) or to obtain the U.S. ENERGY STAR certification. The following sections explain how correct measurement practices ensure products comply with global regulatory and energy efficiency requirements.

Standby Power Measurement According to IEC 62301 Ed.2		
Item	Reference Section	
Supply Voltage Requirements	IEC 62301 Ed.2 Section 4.3	Section 4.3: Supply Voltage
Measurement Uncertainty	IEC 62301 Ed.2 Section 4.4	Measurement Uncertainty
Power Measurement Procedure	IEC 62301 Ed.2 Section 5.3	Power Measurement Methods
Test Report Requirements	IEC 62301 Ed.2 Section 6	Documentation
Power Analyzer Technical Requirements	IEC 62301 Ed.2 Section B.2	Instrument Characteristics

In-depth Analysis of IEC 62301 Ed.2 Standby Power Standard

▼ Supply Voltage Requirements

| IEC 62301 Ed.2 Section 4.3 (Section 4.3: Supply Voltage)

IEC 62301 Ed.2 explicitly requires that supply voltage conditions simulate the power grid parameters of the country of use and mandates the following conditions:

Rated Voltage Tolerance	±1%
Frequency Tolerance	±1%
Total Harmonic Content (THC) Total Harmonic Content <ul style="list-style-type: none">• THC evaluates the "total harmonic content" of the power supply quality• Only the first 13 harmonics (2nd to 13th) are counted	Should be less than 2% (excluding the fundamental)
Voltage Crest Factor (Ratio of Peak to RMS) <ul style="list-style-type: none">• For each power measurement, RMS, measured harmonics (recommended up to the 13th), and confirmation that the crest factor is within the specified range must be recorded simultaneously• The IEC standard allows using programmable AC sources or AC regulators with filters to ensure power supply quality	IEC 62301 Ed.2 requires the supply waveform crest factor to be between 1.34 and 1.49

In-depth Analysis of IEC 62301 Ed.2 Standby Power Standard

▼ Measurement Uncertainty

| IEC 62301 Ed.2 Section 4.4 (Measurement Uncertainty)

In real-world testing, the input current waveform of electrical devices often exhibits distortion and phase shift. Especially in standby mode, current spikes are high (high crest factor) and current is out of phase with voltage (low power factor), making it difficult for a power analyzer to accurately determine actual energy consumption.

To address this uncertainty, IEC defines the Maximum Current Ratio (MCR) as an indicator reflecting both distortion and phase shift:

$$\text{MCR} = \text{Crest Factor} \div \text{Power Factor}$$

Before measurement, the device's crest factor and power factor should be determined to calculate the MCR. Then, according to the classification table in IEC 62301 Ed.2 Section 4.4, the accuracy class of the power analyzer should be selected.

MCR	MCR ≤ 10		MCR > 10	
	Measured Power ≥ 1.0 W	Measured Power < 1.0 W	Measured Power ≥ 1.0 W	Measured Power < 1.0 W
Maximum Permissible Relative Uncertainty (Umr)	≤ 2%	Maximum error allowed 0.02W	≤ U _{pc}	The greater of U _{pc} × P or 0.02 W
Confidence Level	95%	95%	95%	

In-depth Analysis of IEC 62301 Ed.2 Standby Power Standard

▼ Power Measurement Procedure | IEC 62301 Ed.2 Section 5.3 (Power Measurement Methods)

IEC 62301 Ed.2 specifies the following three methods for measuring standby power

IEC 62301 Ed.2 Standby Power Measurement Methods		
Direct Meter Reading Method	Average Reading Method	Sampling Method
Measurement		
Directly read the power value from the front panel of the power analyzer	<ol style="list-style-type: none"> ① Perform two or more measurement cycles, each lasting at least 10 minutes ② Calculate the average power for each cycle ③ Determine the power change rate (mW/h) between the two averages 	<ol style="list-style-type: none"> ① Record power data at a rate faster than once per second ② Keep the device under power for at least 15 minutes ③ Discard one-third of the data (remove the first 5 minutes) ④ Perform a least-squares linear regression on the remaining data to determine the power change trend. <p>(Refer to the table below – Linear Regression Analysis)</p>
Applicable Products		
Limited to devices with highly stable power output, such as fixed-brightness LED lights.	Applicable to devices with moderately stable power output.	Applicable to all load types, including smart devices with intermittent operation.
Limitations		
Suitable only for rapid prototype testing during development; not applicable for variable loads or regulatory reporting.	Test personnel must monitor power stability to ensure the validity of the measurement.	IEC recommends prioritizing this method.

When measuring standby power, IEC 62301 Ed.2 emphasizes that the power data must be sufficiently stable for the measurement to be valid.

In the sampling method, linear regression analysis is applied. Measured power data are plotted (X-axis: time; Y-axis: power), and a line that best fits these points—the least-squares linear regression line—is drawn. The slope of this line indicates the rate of power change. IEC 62301 Ed.2 provides the following classification table to determine whether this regression line is “nearly horizontal,” meaning the power is stable.

Allowed Power Change Rate = Slope	Power Condition	
	Measured Power ≤ 1W	Measured Power > 1W
	Change less than 10mW/h per hour	Change less than 1% of the average power per hour

Example
 If the measured device average power is 0.8 W
 → the slope must not exceed 10 mW/h to be considered stable.

If the measured device average power is 3.5 W
 → the slope must be below $3.5 \text{ W} \times 1\% = 35 \text{ mW/h}$ to be considered acceptable.

▼ Test Report Requirements | IEC 62301 Ed.2 Section 6 (Documentation)

IEC 62301 Ed.2 Section 6 specifies that the test report must include the following information

v	Test equipment name, model, and calibration status
v	Device under test model, software version, and operating status (e.g., network enabled)
v	Supply Conditions (Voltage, Frequency, Waveform Quality)
v	Basis for Measurement Method Selection (Direct Reading / Average Reading / Sampling)
v	Test Duration and Measured Average Power (W)
v	Method and Value of Measurement Uncertainty Evaluation

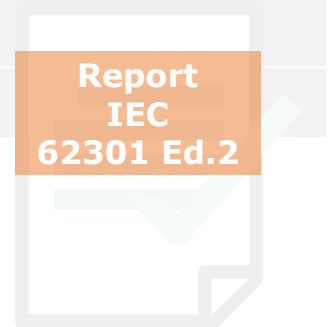

In-depth Analysis of IEC 62301 Ed.2 Standby Power Standard

▼ Power Analyzer Technical Requirements | IEC 62301 Ed.2 Section B.2 (Instrument Characteristics)

MICROTEST 7140 Power Analyzer

Meets the functional requirements for power analyzers specified in IEC 62301 Ed.2

IEC 62301 Ed.2 Requirements for Power Analyzers	MICROTEST 7140	
Equipped with Energy Integration Function	✓	Compliant
Energy Resolution $\leq 1\text{mWh}$	✓	Energy Resolution $100\mu\text{Wh}$
Elapsed Time Resolution $\leq 1\text{s}$	✓	Compliant
Power Resolution $\leq 1\text{mW}$	✓	Compliant
Crest Factor ≥ 3	✓	Supports CF3 and CF6
Minimum Current Range $\leq 10\text{mA}$	✓	Minimum Current Range ($50\mu\text{A} - 11\text{mA}$)
Supports Automatic Overrange Warning Function	✓	Compliant
Capable of Disabling Auto-Range Function	✓	Compliant
Active Power Includes Both AC and DC Components	✓	Compliant
Harmonic Bandwidth $\geq 2.5\text{ kHz}$	✓	Compliant, and supports 100th-order Harmonic Analysis

MICROTEST 7140 Power Analyzer

500 kSPS High-Speed Sampling for precise capture of instantaneous power

Up to 10,000 hours energy integration function for accurate Wh average power estimation

Includes F71201 AC mains fixture with “Low Current” mode for accurate standby power measurement

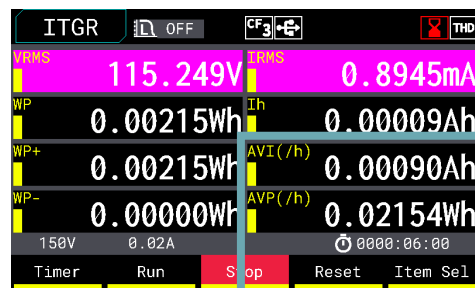
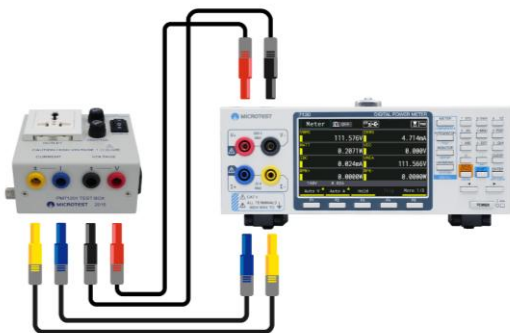

AVI/AVP

Standby power involves low current and low power, so proper range selection and wiring (U-I / I-U) are needed for accurate measurement.

MICROTEST 7140 with F71201 fixture offers a “Low Current” mode that deducts meter power, ensuring standby power is measured accurately near 0 W.

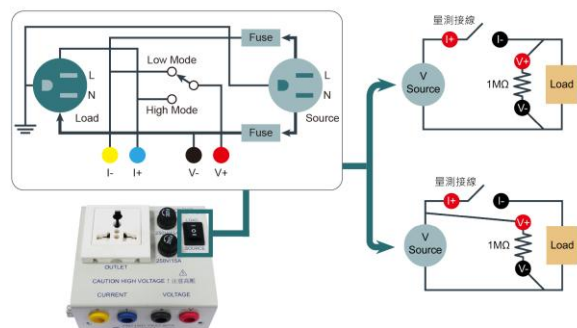

Accurate Standby Power Measurement with Proper Wiring

Compliant with IEC 62301 Ed.2 Standby Power Measurement Requirements

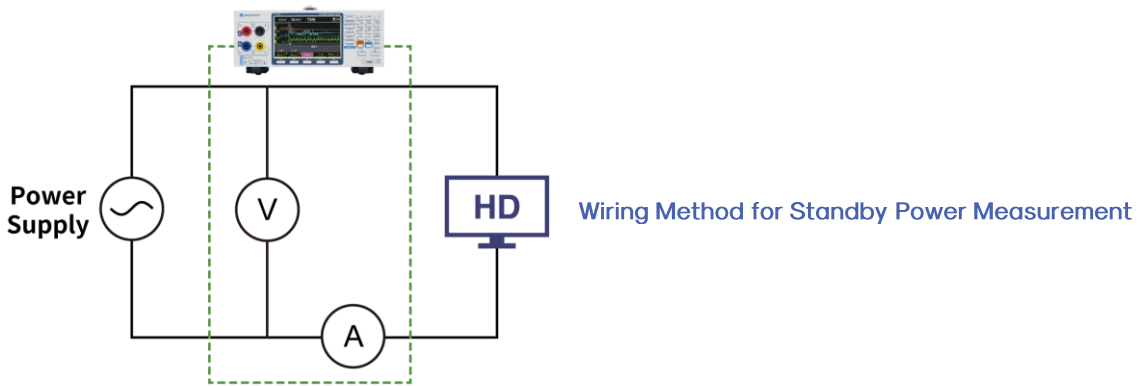

According to IEC 62301 Ed.2 Section B.4, the following connection requirements should be observed during standby power testing:

- ① The power supply must comply with IEC 62301 Section 4.3, typically using a programmable AC source to provide stable and adjustable voltage and frequency
- ② The measurement device—MICROTEST 7140 power analyzer—meets IEC 62301 requirements for measurement uncertainty and resolution

7140 Power Analyzer	V	Basic Measurement Accuracy $\pm 0.05\%$
	V	Energy Resolution $10\mu\text{Wh}$
	V	Power Resolution $\leq 1\text{mW}$
	V	Elapsed Time Resolution $\leq 1\text{s}$

- ③ The power supply, power analyzer, and device under test must all be **safely grounded** to protect personnel and prevent electrical noise interference
- ④ During testing, power data should be recorded at least once per second, ensuring continuity and completeness

MICROTEST 7140 Power Analyzer – Accurately Measures True Standby Power

Addresses three major challenges: Handles spikes, pulses, and low-PF waveforms



Low Power Factor



CF6 Crest Factor



500kSPS
Captures Pulse Currents



Up to 10,000 Hours
Energy Integration

High Accuracy Maintained Even at Low Power Factor

When a device is in standby, it still consumes a small amount of power under minimal load. Most of the current comes from large input filter capacitors (e.g., X2 or energy storage capacitors), which produce current that is almost out of phase with the voltage. In simple terms, capacitive loads cause current to lead voltage, resulting in a very low power factor and making accurate standby power measurement more challenging.

MICROTEST 7140 power analyzer maintains accuracy within $\pm 0.1\%$ under low power factor conditions, enabling precise measurement of standby power even at low power factor.

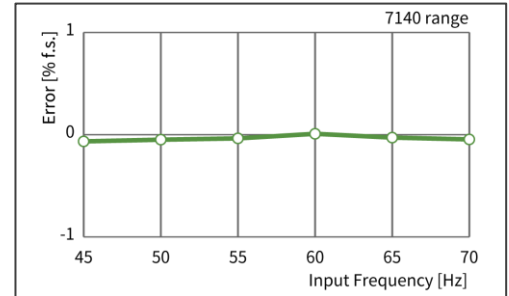

At high crest factors, current peaks are very sharp; the MICROTEST 7140 supports CF6

When a device enters standby, sleep, or light-load operation, the rectification and filtering circuits inside the power supply only conduct when the AC voltage reaches its peak, rapidly charging the energy storage capacitors. At this moment, the current is no longer smooth and continuous but becomes intermittent pulse current, with significant waveform distortion compared to an ideal sine wave, resulting in a very high crest factor (CF).

MICROTEST 7140 power analyzer supports up to CF6 and a minimum range of 2.5 mA, effectively capturing the high-peak current waveforms during standby.

CF6 Current Range	
2.5mA	0.015A
5mA	0.03A
10mA	0.06A
25mA	0.15A
50mA	0.3A
100mA	0.6A

Pulse Mode for Accurate Instantaneous Power, Long-Term Watt-Hour Tracking

When a device is in standby or under light load, the power supply often enters a “pulse mode,” where current flows as irregular pulses. The supply stops drawing new power while the output voltage is sufficient, letting the output filter capacitors slowly release energy. When the voltage drops below a set level, the switching components quickly resume charging. This results in segmented pulse currents with varying amplitude and width.

MICROTEST 7140 power analyzer uses high-speed 500 kSPS continuous sampling to capture all power without loss and supports up to 10,000 hours of energy integration for Wh average power estimation.

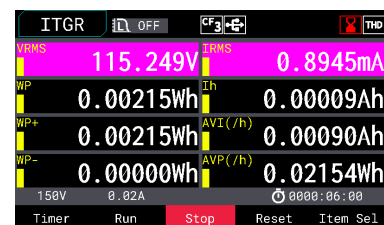
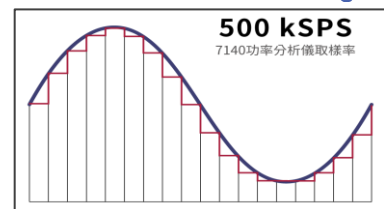

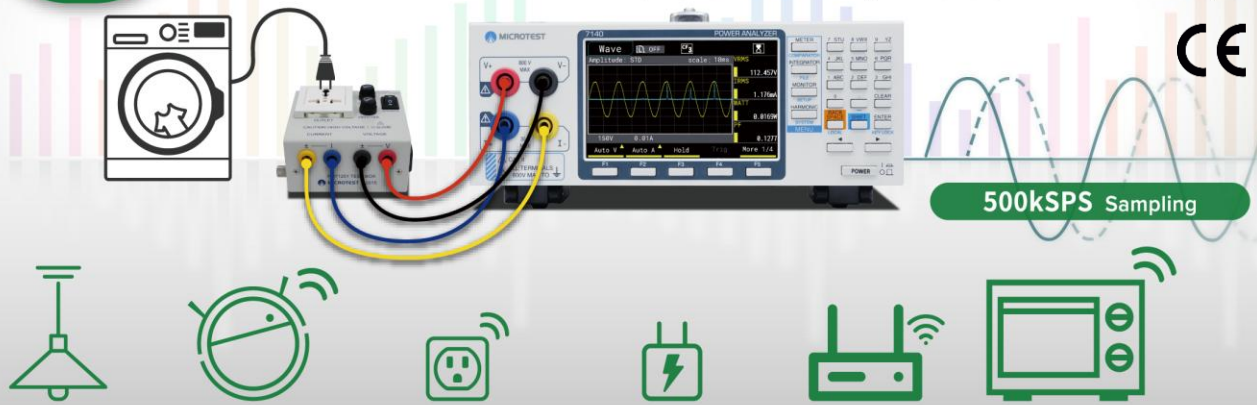

To ensure energy-efficient designs meet compliance, a high-accuracy, high-speed power analyzer is required. The MICROTEST 7140 is designed for single-phase AC/DC power measurement and analysis, with a test bandwidth of DC, 0.2 Hz–100 kHz, 500 kSPS sampling rate, and basic power accuracy of $\pm 0.05\%$. It supports direct input up to 800 V and 30 A, 100th-order harmonic analysis, and simultaneous energy integration, significantly improving testing efficiency.

Function

- Ultra-High Accuracy $\pm 0.05\%$
- $\pm 0.05\%$ Ultra-High Accuracy
- Bandpass / Highpass / Lowpass Filter Support
- Bandpass / Highpass / Lowpass Filters
- Custom Scale Display (UserScale)
- Custom Scale Display (UserScale)
- High-Speed 500 kSPS Sampling
- High-Speed 500 kSPS Sampling
- 100th Harmonic Analysis Support
- 100th Harmonic Analysis
- AC+DC Simultaneous Measurement & Display
- AC+DC Simultaneous Measurement & Display

Measurement Parameters	7140 Measurement Range				
	Max 800V (Direct Input)		Max 30A (Direct Input)		Current External Sensor
	CF3	CF6	CF3	CF6	CF3
Voltage (VRMS/ VDC/ V+PK/ V-PK)					
Current (IRMS/ IDC/ I+PK/ I-PK)					
Frequency (VHZ/ IHZ)					
Power (P)					
Average Power (AVP)					
Integrated Current (AVI)					
Crest Factor (CFV/ CFI)					
Power Factor (PF)					
Apparent Power (S)	15V	7.5V	5mA	2.5mA	500mV 1V 2V 5V 10V
Reactive Power (Q)	30V	15V	10mA	5mA	
Phase Angle (DEG)	60V	30V	20mA	10mA	
Total Harmonic Distortion (THDV/ THDI/ THDW)	150V	75V	50mA	25mA	
Maximum Current Ratio (MCR)	300V	150V	100mA	50mA	
Displacement Power Factor (DPF)	600V	300V	200mA	100mA	
			0.5A	0.25A	
			1A	0.5A	
			2A	1A	
			5A	2.5A	
			10A	5A	
			20A	10A	

- ✓ High Measurement Accuracy $\pm 0.05\%$
- ✓ Sampling Rate up to **500kSPS**
- ✓ Advanced Harmonic Analysis up to the **100th Order**
- ✓ Compliant with **IEC 62301 Standby Power** Measurement
- ✓ Multiple Graph Modes: **Waveform, Trend, and Bar Charts**
- ✓ Exclusive Filtering Functions: **High-Pass and Band-Pass**



Essential for Switching Power Supply Design – Band-Pass Filter Function

Common Switching Power Supply (SMPS) Designs

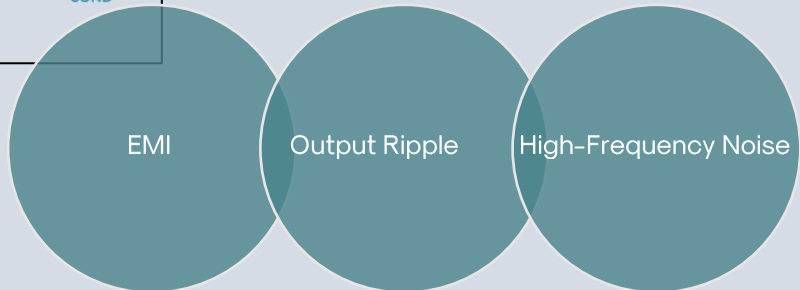
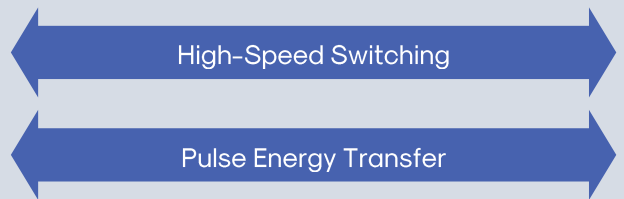
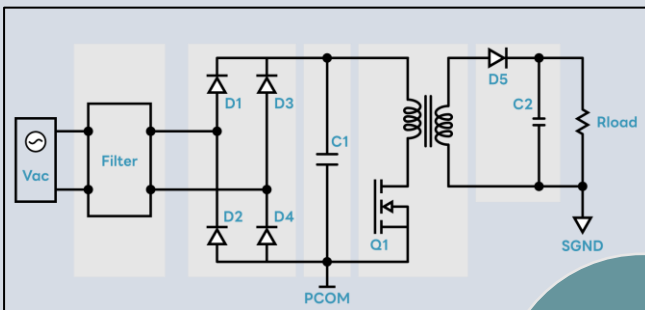

During SMPS design and testing, measurements are often affected by ripple and high-frequency switching noise. A power analyzer with band-pass filter support allows engineers to isolate or retain specific frequency bands, focusing on the target signal and enabling more accurate power and energy quality measurements.

AC Source– Before Filtering

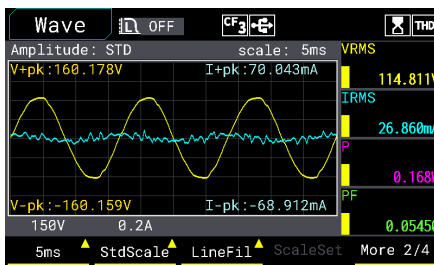

After Filtering

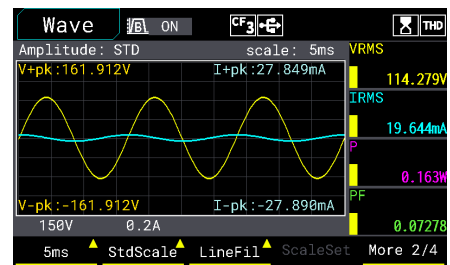

High-speed switching and pulse energy transfer in SMPS generate significant high-frequency noise. Ripple and EMI can mask the true power waveform, leading to inaccurate measurements.

When the power analyzer activates the band-pass filter, only signals within the selected frequency range pass through. This effectively removes interference from low-frequency power or high-frequency switching, smoothing voltage/current waveforms and enabling accurate analysis of harmonics and waveform distortion within the target frequency band.

Essential for Switching Power Supply Design – High-Pass Filter Function

AC Source- Before Filtering

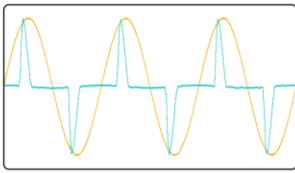

HPF-500Hz

After Filtering

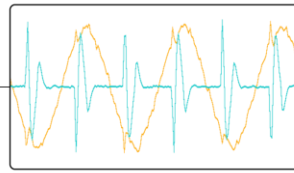

Focus on high-frequency signals above 500 Hz

HPF-5kHz

After Filtering

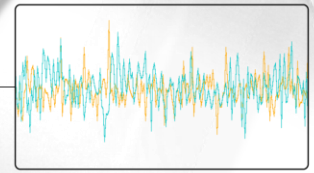

Focus on high-frequency signals above 5 kHz

The core operation of a switching power supply converts AC mains to DC, then uses high-speed MOSFETs or IGBTs for pulse modulation, followed by transformation and filtering to output stable DC. Since switching frequencies range from tens to hundreds of kHz, the input generates significant high-frequency current pulses and harmonics.

Using a standard power analyzer to measure PF or current waveforms may suppress or mix these high-frequency components with the fundamental, resulting in inaccurate power factor and current waveform readings.

Activating the high-pass filter allows isolated observation of high-frequency noise, enabling analysis of its impact on power factor, grid interference, and EMI.

AC Source- Before Filtering

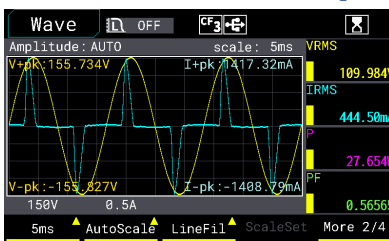

HPF ON-500Hz

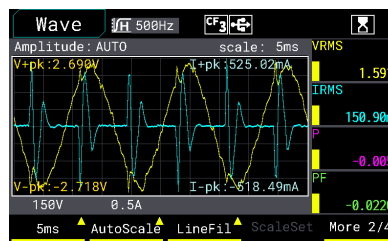

HPF ON-5kHz

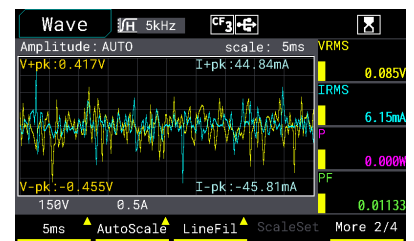

Power Analyzer with High-Pass Filter Function

Analyzes high-frequency signals above 500 Hz / 5 kHz

When measuring a power supply, connect to the AC source and enable the high-pass filter. By setting frequency bands at 500 Hz, 5 kHz, and 100 kHz, engineers can analyze current fluctuations in different high-frequency ranges.

This helps clearly identify high-frequency harmonics and noise at the power supply input and determine which frequency bands most affect power quality and equipment stability.

7140 Power Analyzer | Powerful Features



R&D

Graph Analysis Mode

Supports 100th-Order Harmonic Analysis and Energy Integration Simultaneously on Any Display Background

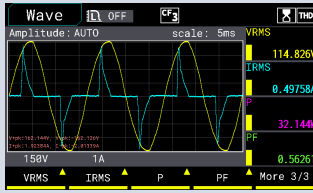

Voltage/Current Waveform Chart

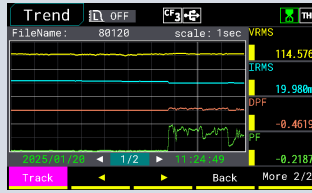

Scrollable Time Axis for Quick Trend Analysis

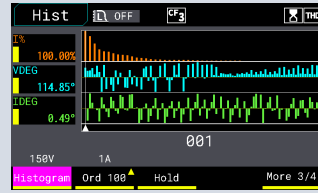

Supports 100th-Order Harmonic Analysis with Bar Chart Display

7140 Power Analyzer Accurately Analyzes DC Components in AC Signals

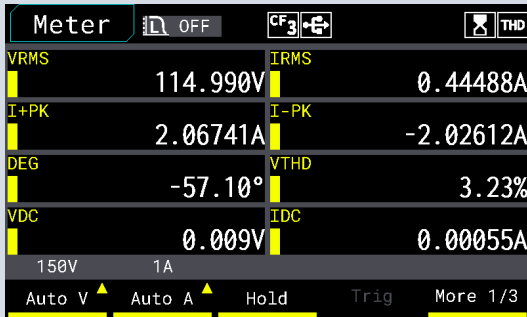

According to IEC 62301:2011 Section B6, standby power measurements must include the DC component of the current waveform in the power calculation. In standby mode, the load may conduct during only one half-cycle of the AC voltage, producing an asymmetric current waveform that contains a DC component. Excluding this component would underestimate power consumption and compromise the accuracy of energy efficiency assessments.

Production Line



Up to 10,000 Hours Energy Integration Function

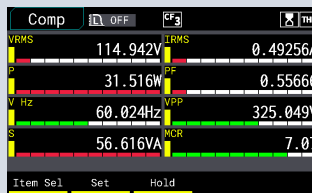

Set Upper and Lower Limits for Automatic PASS/FAIL Evaluation

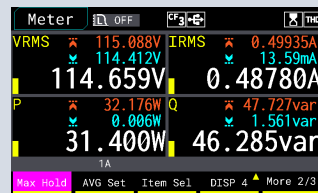

Monitor Maximum and Minimum Values

MICROTEST 7140 | Best Value Choice in the Industry

Ultra-High Accuracy | Advanced Filtering | 100th-Order Harmonic Analysis Capability

Comparison Chart

Power Analyzer | 100kHz (Single Phase)



BRAND	MICROTEST	ROHDE & SCHWARZ	ITECH
MODEL	7140	NPA501	IT9121
Phase Type	Single Phase	Single Phase	Single Phase
Channel	Single Channel	2 Channels	Single Channel
Frequency Bandwidth	DC, 0.2Hz~ 100kHz	DC~100kHz	DC, 0.5Hz~ 100kHz
Basic accuracy	±0.05%	±0.05%	±0.1%
Sampling Rate	500kSPS	500kSPS	100kSPS
Harmonic Analysis	100th	50th	50th
High-Pass Filter Band-Pass Filter	●	/	/
Graph Mode	Waveform Trend Bar Graph	Waveform Bar Graph	Waveform
PASS/FAIL Comp	●	●	/
Voltage Input	800V	600V	600V
Current Input	30A	20A	20A
Display	4.3" TFT LCD	3.5" TFT LCD	4.3" TFT LCD
Standard Interface	RS-232 USB Device USB Host LAN SIGNAL I/O	RS-232 USB Device USB Host LAN	RS-232 USB Device USB Host LAN

MICROTEST CORPORATION

Guardian of Global Product Electrical Quality Over 30 years



sales@microtest.com.tw



Measurement Insights